

ŞEKILLENDİRİŞ SUNGATY

*Umumy orta bilim berýän mekdepleriň
2-nji synpy üçin derslik*

Gaştadan işlenen we doldurylan
başinji neşir

*Özbekistan Respublikasynyň Halk bilimi
ministrligi tarapyndan tassyklanylan*



**Çolpan adyndaky neşirýat-çaphana döredijilik öýi
Daşkent – 2018**

UO'K 372.87=512.164(075)

KBK 85.15ya71

T 27

Awtorlar:

**M. Isakowa, R. Hasanow, B. Haýdarow,
A. Suleýmanow, S. Jumaniýazowa, A. Rozikow**

Syn ýazanlar:

R. Hudaýberganow – Özbegistanyň halk hudožnigi, K. Behzat adyndaky Milli suratkeşlik we dizaýn institutynyň professory;

G. Zulhaýdarowa – Respublikan tälim merkeziniň metodisti;

N. Haýtanowa – Daşkent şäheriniň Mürze Ulugbek tümeniniň 187-mekdebiniň mugallymy.

B. Ýunusowa – Daşkent şäheriniň Ýunusabat tümeniniň 43-mekdebiniň mugallymy.

ŞERTLI BELGILER:



– ugrukdyryjy sorag we ýumuşlar



– öwrenmeli we ýatda saklamaly material



– amaly iş we ýumuşlar



– öýe berlen ýumuşlar



– gyzykly ýumuşlar



– zehinliler üçin ýumuşlar



– gaýtalamak üçin sorag we ýumuşlar



– dersiniň soňy

Respublikanyň ýörite kitap gaznasynyň serişdeleriniň hasabyndan çap edildi

© M. Isakowa we başg. 2018

© Çolpan adyndaky NÇDÖ, 2016

© Çolpan adyndaky NÇDÖ, 2018

Türkmen diline terjime edildi.

ISBN 978-9943-05-837-8

I ÇÄRÝEK



P. Tohirow. *Altyn güýz*

Şu çärýekde siz:

- gara galam, çotga we reňkler bilen işlemegi dowam etdirersiňiz;
- esasy reňklerden reňk almaga degişli başarnygyňyzy ösdürersiňiz;
- tebigy peýzažyň suratyny çekersiňiz;
- amaly sungat barada düşünjä eýe bolarsyňyz;
- suratkeşler tarapyndan çekilen natýur-mortlary düşünmegi öwrenersiňiz.

1-NJI SENTÝABR — ÖZBEGISTANYŇ GARAŞSYZLYGY GÜNÜDIR



«Ýagşylyk arkasy» — Garaşsyzlyk meýdanyndaky heýkeltaraşlyk kompozisiýasy.

REŇKLER WE ÖWÜŞGINLER

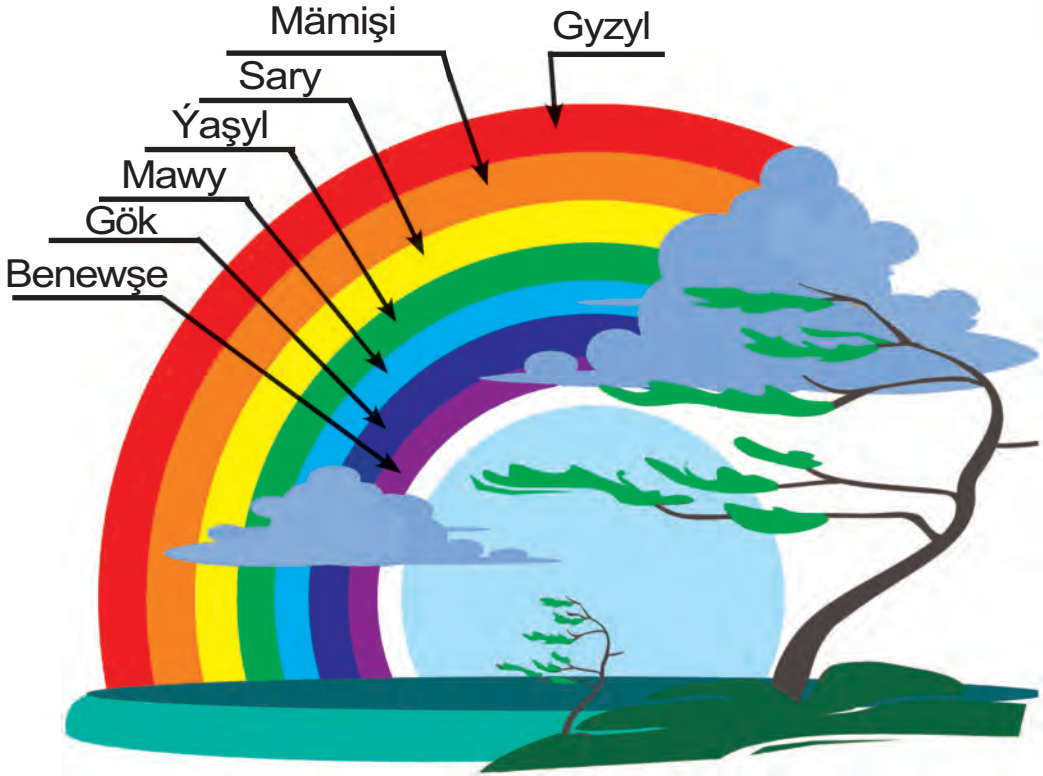

1. Älemgoşar asmanda haçan peýda bolýar?
2. Älemgoşar nähili reňklerden ybarat?

Älem reňklerden doly. Emma tebigatda esasy üç: sary, gyzy we gök reňkler bolup, galan reňkler şol reňkleri bir-birine goşmak netijesinde alynýar.





Esasy reňkler.



Sary



Gyzyl



Gök

Esasy reňkleriň öwüşginleri.

Reňke köpräk suw goşulsa açyk reňkler — reňkiň öwüşginleri emele gelýär.

Sary

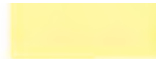

Açyk sary reňkler

Gyzyl



Açyl gyzyl reňkler

Mawy

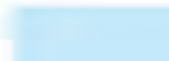

Açyk gök reňkler

Çekilen suratlary reňklemek üçin akwarel reňkler ulanylýar.



Akwarel — suwda ereýän boýag.





Reňkleriň simwoliki manysy:

Şekillendiriş sungatynda reňkleriň simwoliki manylaryndan hem peýdalanylýar:



– ene tebigatyň simwoly;



– asmanyň, älemiň we parahatçylygyň simwoly;



– ýeňiş, ýalyn, şadyýanlyk simwoly;



– mukaddeslik, ýagtylyk, güneş simwoly;



– matam, gorky, sussypeslik simwoly;



– päklik, azatlyk, bagt simwoly.

Çotga şeýle tutulýar.



Uly üstler
boýalanda.



Inçe, dar ýerler
boýalanda.



Siz haýsy reňki halaýarsyňyz? Näme üçin?
Düşündirip beriň.





Surat çekmegiň esasy basgançaklary.

1-nji basgançak. Şekili kagyza ýerleşdirmek.

Suratlandyrylýan zadyň boýuny we inini deňşdirip, şekiliň kagyza dikligine ýa-da keseligine ýerleşdirilmelidigi anyklanýar.

Zadyň şekiliniň orny, onuň boýy we ininiň gatnaşygyny üýtgetmezden kagyzyň ortasyna çyzyklar bilen çekilýär.



2-nji basgançak. Galamda ilkinji işlemek.

Zadyň gurluşy, esasy bölekleriniň ýerleşişini anyklanýar we kömekçi çyzyklar çyzylýar.



3-nji basgançak. Galamda ahyrky bezeg bermek.

Galamda suratlandyrylýan zadyň esasy böleklerine we maýda böleklerine galamda bezeg berilýär. Kömekçi çyzyklar öçürlip taşlanýar.

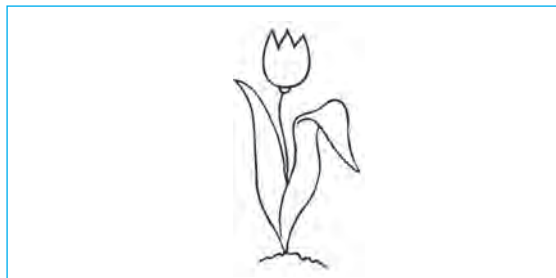

4-nji basgançak. Boýaglar bilen bezemek.

Zadyň suratyny ilki açyk reňklere, soňra doýgunrak reňklerde bezeg berilýär. Ahyrynda suratyň bölekleri aýdyň boýaglar bilen işlenilýär.



Ýokardaky görkezmeler esasynda güneşiň suratyny çekiň.



Şekiliň kagyzdaky orny nähili anyklanýar?



MIWELERİŇ SURATYNY ÇEKMEK



G. Abdurahmanow. *Güýzüň nygmatlary*

Suratkeş Gafur Abdurahmanowyň natýurmortynda güýzki miwelerden alma, armyt, garaly, bakja ekinlerinden garpyz we gawun şekillendirilen. Olaryň şeklini we reňklerini ünsli synlaň. Siz hem çeken suratyňyzda şeýle reňklerden peýdalanmaga çalyşyň.



Natýurmort «jansyz tebigat» diýen many aňladyp, onda öý-hojalyk goşlary, miweler, gök önümler, güller ýaly zatlar suratlandyrylýar.



A. Bakirow. *Narlar*



Ýu. Elizarow. *Gawunlar*

Miweleriň we zatlaryň suratyny aýry-aýry çekmegiň zygiderlili.



Almanyň suratyny çekmegiň zygiderliliği.

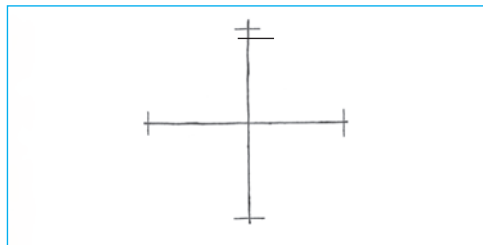

Şekiliň ölçeglerini kesgitlemek.



Galamda ilkinji işlemek.



Galamda soňlama işlemek.
Kömekçi çyzyklary öçürmek.

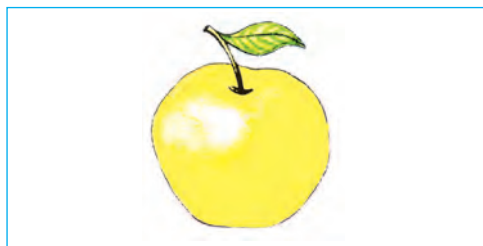

Açyk reňke reňklemek.



Doýgun reňke reňklemek.



Reňkini soňlama işlemek.





A. Ikramjanow. *Üzüm we armytlar*

Güüzüň nygmatlary suratlandyrylan natýurmort çekmek köp uratkeşleriň söýgüli temasy. Suratkeş A. Ikramjanow hem güýzki miweleri ussatlyk bilen suratlandyrypdyr.

Eserde armyt, alma, üzüm ýaly miweleriň reňkleri ussatlyk bilen çekilipdir. Olar edil ýanyň duran ýaly duýulýar.



Alma, garpyz we küzeden ybarat natýurmortyň suratyny işläň.



Jansyz zatlar suratlandyrylan suraty nähili atlandyryarsy?



Miwelerden we milli gaplardan ybarat natýurmort ýönekeýligi bilen surat çekende kynçylyk döredmeýär. Surat çeken mahalyňyzda şu natýurmortdan hem peýdalanyp bilersiňiz.



1. Synpda çekilen natýurmoty akwarel reňkler bilen reňkläň.
- 2*. Öý hojalyk zatlaryndan natýurmort düzüň we onuň suratyny işläň.



PEÝZAŽYŇ SURATYNY ÇEKMEK



F. Abdurahmanow. *Güýki peýzaž*

Kimdir şäherde, kimdir obada ýaşaýar. Her kimiň öz doglup ösen ýeri gözüne gowy görünýär. Şäherler giň köçeleri, döwrebap köprüleri, beýik binalary bilen tapawutlanýar.

Garaşsyzlyk sebäpli obalarda hem şäherlerdäkiden galmaýan ýaşaýyş jaýlary we giň köçeler guruldy.



1. Suratda nämeler suratlandyrylypdyr?
2. Şäher bilen obanyň bir-birinden nähili tapawutlary bar?
3. Öz şäheriňiz (obaňyz) barada aýdyp beriň.



Surat çekmegiň ýönekeý düzgünleri.

Ýerde dik duran zadyň kagyzdaky şekili-de dik bolýar.



Zatlar suratkeşden birmeňzeş uzaklykda duran bolsa, olaryň kagyzdaky şekilleriniň gatnaşygy, hakyky ölçegleriniň gatnaşygy ýaly bolýar.



Nädogry.



Dogry.

Birmeňzeş zat suratkeşden dürli uzaklykda duran bolsa, golaýdaky kagyza ulurak, uzakdakysy kiçiräk suratlandyrylýar. Şekillendiriş sungatynda muňa perspektiwa diýilýär.



Nädogry.

Dogry.



Daragtlar, ot-çöpler we güller bilen örtülen peýzažyň suratyny çekmegiň zygiderligi.

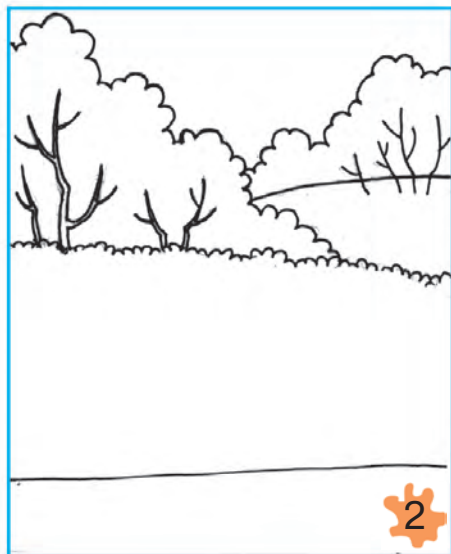
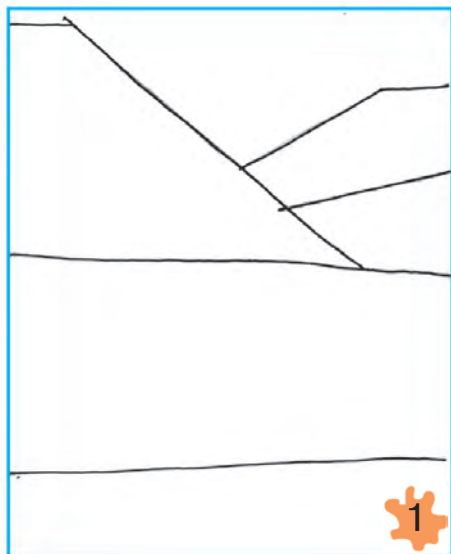

Aşakdaky surata we fotosurata üns berseňiz, daragtlar uzaklaşdygy saýyn kiçelýändigini görersiňiz.



«Meniň şäherim (obam)» temasynda surat çekiň. Surat çekende perspektiwa üns beriň.



1. Perpektiwa näme?
2. Zatlar göze ýakyn ýa-da uzak durandygyna garap nähili suratlandyrylýar?



1. Synpda başlanan «Meniň şäherim (obam)» suratynyň üstünde işlemeği dowam etdiriň we ony akwarelde reňkläň.

- 2*. «Şäherimiziň köçeleri» temasynda özbaşdak surat çekiň.



MUGALLYMLAR BAÝRAMYNA GUTLAG HATY ESKIZINI IŞLEMEK



1-nji oktýabr — Mugallymlar we terbiýeçiler günü. Mugallymlar bize okamagy we ýazmagy öwredýärler. Geljekde gowy adam bolup ýetişmegimizi üpjün edýärler. Bu baýramda olary gutlamagy unutmaly däldiris.



1. Gutlag hatlarynda nämeleri suratlandyrmak mümkin?
2. Ýene nähili gutlag hatlaryny bilýärsiňiz?



Gutlag haty eskizini işlemeğniň zygiderligi.

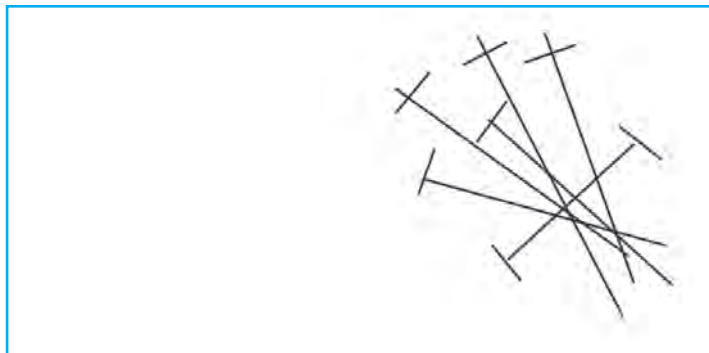

Teswiriň ölçeglerini kesgitlemek.



Teswiri ilkinji işlemek.

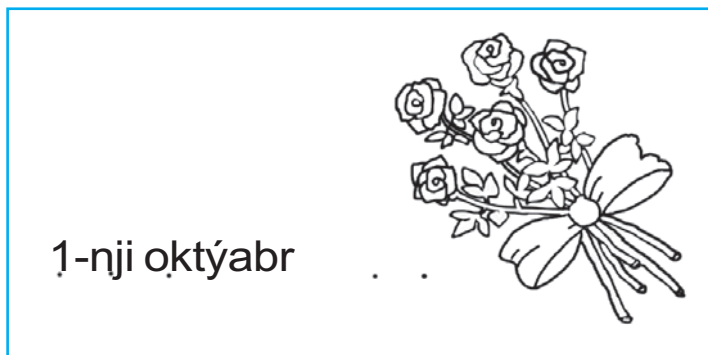

Teswiri galamda tamamlamak.



1-nji oktýabr

Suraty reňk bilen doly çekmek.



Nusgalar esasynda mugallymlar gününe bagyşlanan «Baýramyňyz gutly bolsun» gutlag hatynyň eskizini işläň. Bu gutlag hatyna mugallymyňyza bagyşlap gowy dilegleri-de ýazyp bilersiňiz. Diňe olaryň örän gysga we tüýs ýürekden bolmagyna üns beriň. Mysal üçin: «Baýramyňyz bilen», «Birinji halypama hormat».



Synpda işlenen gutlag haty eskizini doly ýerine ýetiriň.



«KÜLÇE» ERTEKISI ESASYNDA HEÝKEL ÝASAMAK



Külçe

(Erteki)

Külçedirin, külçe men,
Supradaky undan men.
Supuripjik aldylar
Gaýmaga-da gardylar.
Bişirdiler tabada,
Sowatdylar howada.
Gaçyp gitdim babamdan,
Gaçyp gitdim mamamdan.
Senden bolsa towşanjyk,
Gaçyp gitmek
hiç zat däl.





Külçäniň öňünden möjek we aýy hem çykypdyr. Olardan hem aýdymyny aýdyp gutulyppdyr.

Ýöne oňa duşan tilki mekirlilik edipdir:

— Gulagym gwy eşitmeýär. Hany tumşugyma oturyp, aýdymyň aýdym bersen-e, — diýipdir.

Külçe tilkiniň tumşugyna çykyp, indi aýdymyny aýtjak bolanda, tilki ony hap edip, iýip goýupdyr.





Berlen suratlardan peýdalanyňp külçe ertekisiniň gahrymanlarynyň heýkelini ýasaň. Munda olaryň bir-birine görä uly-kiçiligine üns beriň.



Külçe heý keljigini ýasamagyň zygiderligi.

1



Külçe heýkeljiginiň bölümlerine laýyk bölejikler bölünip alynýar.

2



Külçäniň böleklerine şekil berilýär.

3



Külçäniň bölekleri birleşdirilýär we jemleýji işlenýär.



Kompozisiýa diýip, şekilleri bir-birine görä belli bir tertipde ýerleşdirmäge, olary mälim bir tertibe görä birleşdirmäge aýdylýar.



1. Berlen suratlar esasynda synpda ýasalan heýkeljiklerden ybarat kompozisiýa düzüň.
- 2*. «Külçe» ertekisi esasynda surat çekiň.



HALK AMALY SUNGATY

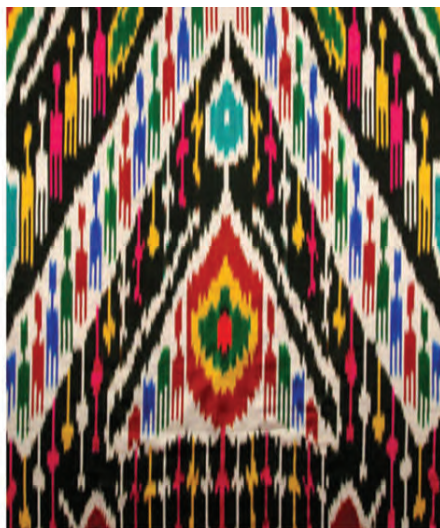



Halk amaly bezeg sungaty durmuşymyзда iň köp ulanylýan sungat görnüşi hasaplanýar. Onuň nakgaşlyk, gençkärlik, agaç nakgaşlygy görnüşleri bar. Şeýle hem, çeper hünärmentçiligiň küýzegärçilik, zerdozlyk, metala nagyş basma, keşdeçilik, halyçylyk, tahyaçylyk görnüşleri adamlaryň durmuşynyň gözel bolmagyna hyzmat edýär. Amaly bezeg sungaty Buhara, Samarkant, Kokant, Margilan ýaly şäherlerde ösen.



1. Suratlarda nämeler görkezilipdir? Olar amaly sungatyň haýsy görnüşine degişli?
2. Siz olara nirelerde duşupdyňyz?



Amaly bezeg sungatynyň görnüşleri.



Zergärlük.

Zerdozlyk.



Küzegärçilik.



Keşdeçilik.



Metala nagyš basma.



Gençkärlik.



Agaç oýmakärligi.



Suratlarda görkezilen halk amaly bezeg sungatynyň nusgalarynda ulanylan elementler barada hekaýa düzüň.



Aşakdaky görkezilen zatlaryň atlaryny aýdyň. Olaryň şeklini, bezeglerini hem-de olardan nähili maksatlarda peýdalanylýandygyny düşündirip beriň.



1. Amaly bezeg sungaty görnüşi ösen haýsy şäherleri bilýärsiňiz?
2. Amaly bezeg sungaty görnüşlerini sanap beriň.
3. Siz ýaşayan ýerde amaly sungatyň haýsy görnüşi ösen?



Amaly sungat önümlerini ýasaýan hünärmentler barada kiçi hekaýa düzüň.



«GÜÝZ GELDI» TEMASYNDA SURAT ÇEKMEK



R. Ahmedow. *Akdaşda güýz*

Ülkämizde altyn güýz öz gözelligini mese-
mälim edýär. Daragtlaryň ýapraklary sary,
mämişi we gyzyl reňklere geçip, tebigat öz-
eçe keşbine girýär. Elbetde bu gözelligi der-
rew kagyza geçiresiň gelýär.

Özbekistanly suratkeşler Nikolaý Karahan, Oral Tansykbaýew, Rahim Ahmedow, Nemat Kozybaýew, Isfandiýar Haýdarow, Gafur Abdurahmanow, Abduwali Möminowlar altyn güýz peýzažyny özboluşly suratlandyrypdyrlar.



1. Suratda haýsy reňkler köpräk?
2. Güýzi näme sebäpden altyna deňeýärler?



Gyzgyn reňkler:



— sary;



— gülgün;



— açyk sary;



— gyzyl.



Gyzgyn reňkler gün we ýalyn reňklerini ýatladýar. Güýz keşbiniň suraty köplenç şu reňklerde suratlandyrylýar.



Peýzaž (manzar) — tebigatyň görnüşi suratlandyrylan surat.



Tebigatyň keşbiniň suratyny çekmegiň yzygiderliligi.

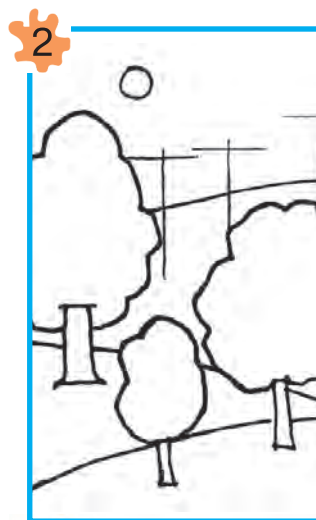
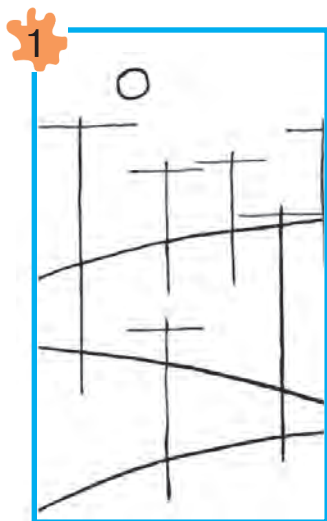

«Güýz geldi» temasynda kiçi hekaýa düzüň we ol esasynda özüňiz göz öňüne getirşiňiz ýaly peýzažyň suratyny çekiň.



**Oral
Tansykbayew**
(1904 – 1974)

Özbekistanyň halk suratkeşi. Manzar žanrynyň usady hökmünde dünýä meşhur. Meşhur eserleri: «Meniň aýdymym», «Dagda bahar», «Dagda», «Angren jülgesi», «Belent dag ýaýlasy» we başgalar.



O. Tansykbayew. *Dagda güyz*



1. Peýzaž suratlarda nämeler şekillendirilýär?
2. Tebigatyň keşbi suratlandyrylan ýene nähili eserleri bilýärsiňiz?



1. Synpda çekilen «Altyn güyz» temasyndaky suraty tamamlan.
- 2* . Göz önüne getirmeleriňiz esasynda «Hasyly baýramy» temasynda surat çekiň.





P. Tahirov. *Senagat zolagy*



ARALYK BARLAG IŞI

I. Test soraglary:

1. Esasy reňkler dogry görkezilen bendi anyklaň:

A

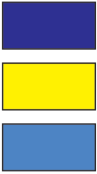

B



Ç

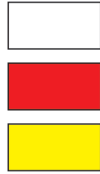

D



2. Haýsy suratda şekil dogry ýerleşdirilipdir?

A



B



Ç



D



3. Aşakdaky suratlaryň haýsylary amaly sungata deňişlidigini anyklaň.

A



B



Ç



D



4. Haýsy suratda gatnaşyk dogry şekillendirilipdir?

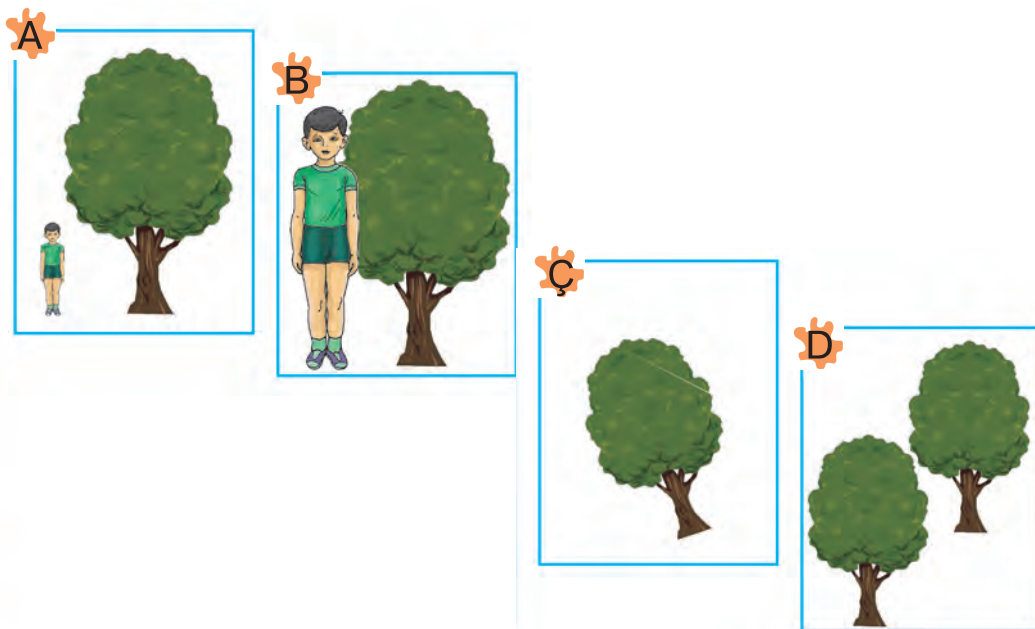

5. Ýyly reňkler dogry görkezilen bendi anyklaň:

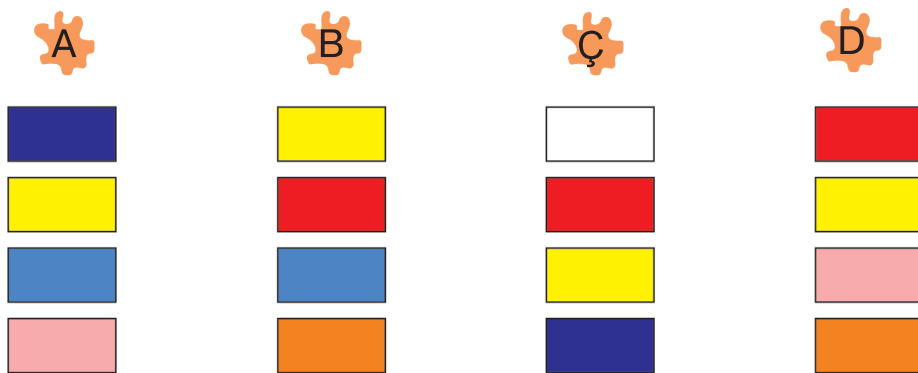

II. Amaly ýumuş.

Peýzažyň suratyny akwarelde reňkläp tabşyrmaly we ol hakda gysgaça hekaýa edip bermeli.

II ÇÄRÝEK



S. Suleýmanow. *Güýz*

Bu çäryekde siz:

- ýol-ýol şekili nagyşlary çekmegi;
- güýzki işler temasynda surat çekmegi;
- ertekiler esasynda heýkeljikleri işlemegi;
- erteki esasynda surat-illýustrasiýa çekmegi öwrenersiňiz.

BALYGYŇ HEÝKELJIGINI ÝASAMAK

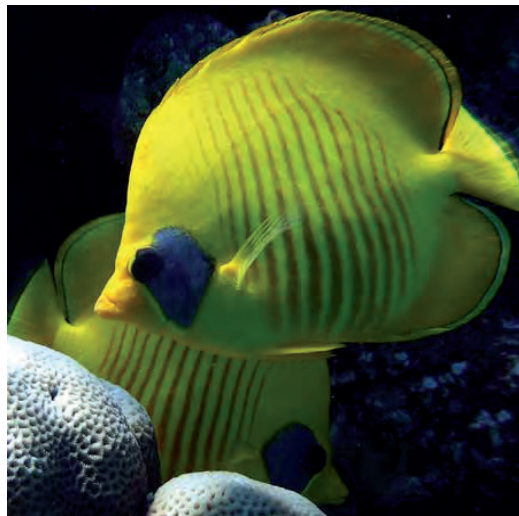

1. Balyklar barada nämeleri bilýärsiňiz?
2. Olaryň görnüşleri, şekilleri we reňkleri nähili bolýar?

Özbekistanda balyklaryň 106 görnüşi ýaýran. Balyklaryň kepir balyk, lakga balyk, çortan, akja, ak amur, gyzył göz, tüňňimaňlaý, ýagbalyk ýaly görnüşlerini özüňiz hem gören bolmagyňyz mümkin. Suwda çalt ýüzýän balyklaryň bedeni süýri, haýal ýüzýänleriňki ýasyrak bolýar. Balyklar bir-birinden uly kiçiligine garap hem tapawutlanýar.



1. Balyklar üçin ýüzgüçleri nähili ähmiýete eýe?
2. Balyklar gury ýerde ýaşap bilerlermi? Näme üçin?



Özüňiz islän balygyň heýkeljigini ýasaň.



S. Redkin. *Balyk natýurmorty*



Balygyň heýkeljigini ýasamagyň zygiderligi.

1



Balygyň heýkeljigi bölümlere laýyk bölekler bölünip alynýar.

2



Balygyň böleklerine şekil berilýär.

3



Balygyň bölekleri birleşdirilýär.

4



Heýkeljigi doly işlemek.



1. Balygyň görnüşlerinden ybarat birnäçe heýkeljik ýasaň.

2*. Özüňize ýakýan balygyň suratyny çekiň.



«GÜÝZKI IŞLER» TEMASYNDA SURAT ÇEKMEK



P. Benkow. *Joralar*

GÜÝZ

Ülkämizde güýz pasly. Bu pasylda alma, üzüm, behi, nar ýaly ençeme miweler bişip ýetişýär. Meýdanlarda pagtalar açylýar. Olary ýygyp almak güýzki işleriň esasyny düzýär.



«Güýzki işler» temasyndaky suraty çekmegiň yzygiderligi.



Teswiri kagyza ýerleşdirmek.



Teswiri kesgitlemek.



Teswiri galamda doly işlemek.



1. Güýzde ýene nähili işler amala aşyrylýar?
2. «Mähirjan baýramy» barada nämeleri bilýärsiňiz?



Teswiri reňk bilen
doly tamamlamak.



«Güýzki işler» temasynda erkin surat çekiň.



M. Saidow. *Üzüm ýygymy*



1. Synpda işlenen «Güýzki işler» temasyndaky
suraty doly tamamlañ.

2*. Güýz temasynda erkin surat çekiň.



ÝOL-ÝOL NAGYŞ ÇEKMEK



Nagyşlara her ädimde duşmak bolýar. Olar bilen binalar we zatlar bezelýär. Nagyşlar güller, miweleriň suraty we başga şekiller esasynda işlenilýär. Nagyşlaryň ýol-ýol, kwadrat, dörtburluk we tegelek görnüşleri bar.



1. Ýokarda görkezilen suratda binanyň daşky we içki bölegi näme bilen bezelipdir?
2. Nagyşlara ýene nirede duşmak bolar?



Nagyşlarda köp duşýan bezeg şekilleri we olaryň atlary.

Nakgaşlykda ulanylýan şekiller, esasan, tebigatdan alynýar. Şonuň üçin olaryň atlandyrylyşy hem meňzeş bolýar. Aşakdaky suratlary görüp, muňa göz ýetirýäris.



ýaprak



ýaprak



üçýaprak



burç



pagta



bofta



buýra



aýgül



aýgül

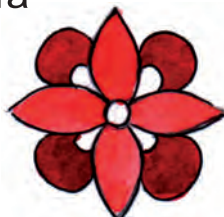

aýgül



gwozdika



Ýol-ýol nagyşlar.

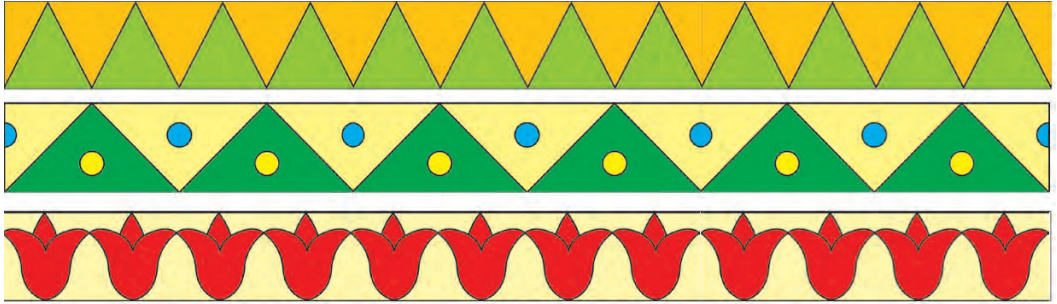

Ýokardaky nagyşlar ýol-ýol nagyşlara mysal bolup biler. Olaryň görnüşi uzyn ýola meňzeýär. Şonuň üçin hem olar ýol-ýol nagyşlar diýlip atlandyrylýar.



Ýol-ýol nagyşlary çekmegiň zygiderligi.

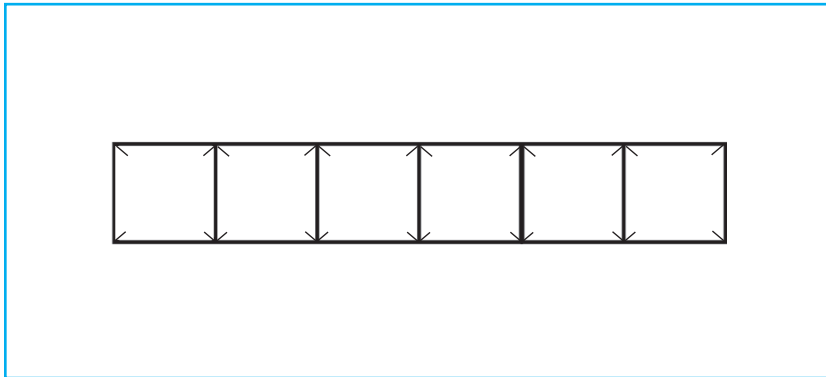

Kagyz listi üçe bölünýär, nagyş ýoly we gözenekleri belgilenýär.

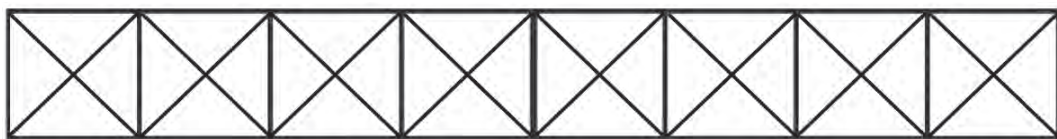

Esasy nagşyň elementini çekmek.



Esasy nagşy gaýtadan çekmek.



Nagşy boýamagyň yzygiderligi.



1-nji basgançak.



2-nji basgançak.



3-nji basgançak.



1. Nagşlar näme maksatda işlenýär?
2. Daş-töweregiňizden ýol-ýol nagşlara mysal tapyň.



**Ussa Şirin
Muradow**
(1879–1957)

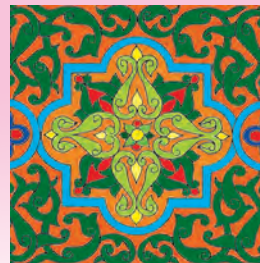

Ussa Şirin Muradow — binagär, bezegçi ussa, Özbekistan Ylymlar Akademiýasynyň hormatly agzasy, Özbekistanda at gazanan sungat işgäri. Gençkärlikde ýol-ýol nagyş kompozisiýalaryny köp ulanypdyr. «Buyuk xizmatlari uchun» ordeni bilen sylaglanan (2001-nji ý.)



Nusga boýunça başgaça görnüsdäki ýol-ýol nagyş çekiň. Onda ýapraklaryň we gülleriň teswirlemegi mümkin.

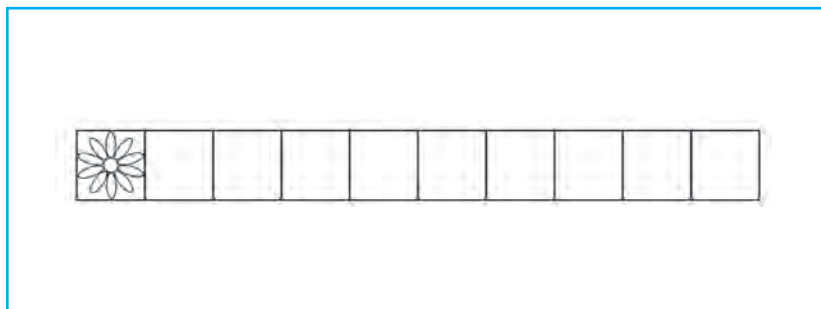

1. Synpda işlenen ýol-ýol nagyşy reňkläň.
- 2*. Haýsy-da bolsa bir zatdaky ýol-ýol nagyşdan nusga alyň.



«TILKI BILEN MÖJEK» ERTEKISI ESASYNDA HEÝKEL ÝASAMAK

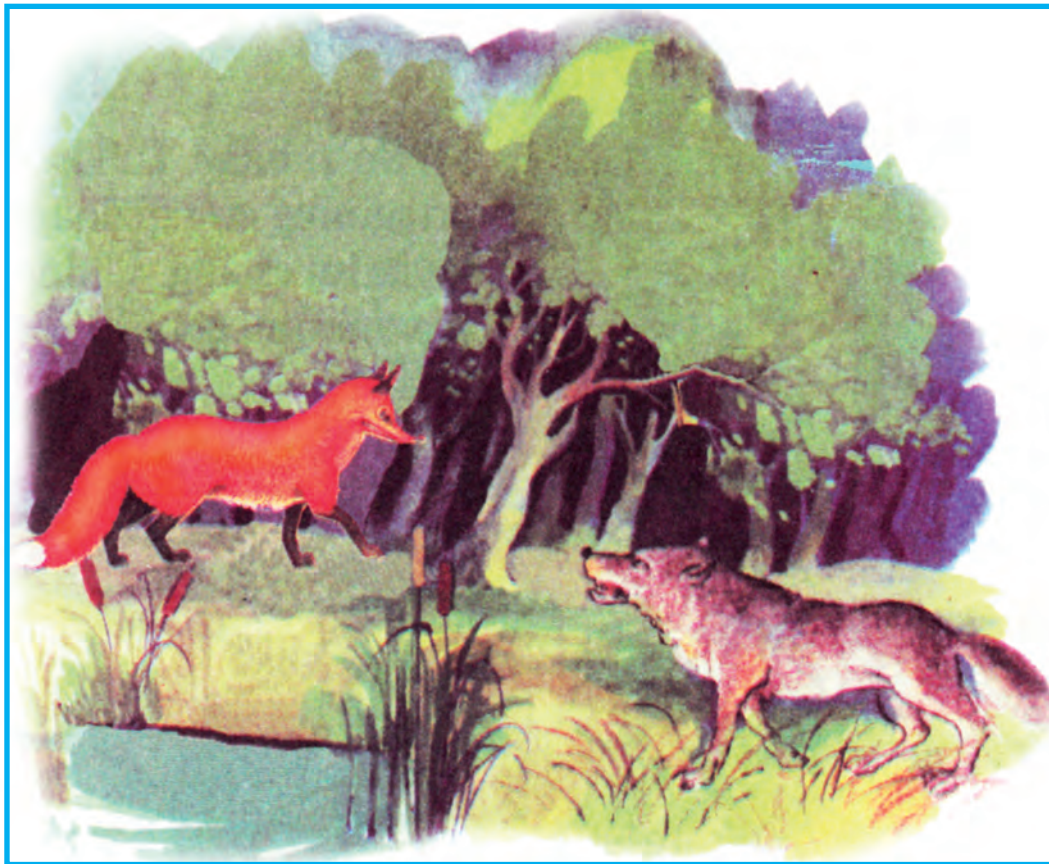

Tilki bilen möjek

Tilki bilen möjek ýakyn dost eken... Tilki möjegi üzüm ogurlamaga eltipdir. Tilki biraz üzüm iýensoň, iki sany üzümi burnuna dykyp:



«Men şeýle köp üzüm iýipdirin weli, hatda burnumdan çykyp barýar. Senem doýup iýgin, burnuňdan çykar», — diýipdir.

Möjek gaty köp üzüm iýse-de burnundan çykmandyr. Onuň garny çişip ýykylypdyr.

Tilki bolsa: «Üzüme ogry düşdi», — diýip gygyrypdyr. Muny eşiden bagban gelip möjegi

taýak bilen gowuja ýenjipdir. Şol günden başlap möjek tilkä hiç hili haýyş etmeýän bolupdyr.



«Tilki bilen möjek» ertekisiniň gahrymanlarynyň heýkeljiklerini ýasaň.



Tilkiniň heýkeljigini ýasamagyň zygiderligi.

1



Tilkiniň heýkeljigi bölümlere laýyk böleklere bölünip alynýar.

2



Tilkiniň böleklerine şekil berlip, birleşdirilýär.

3



Tilkiniň maýda bölekleri birleşdirilýär.

4



Heýkeljik doly işlenýär.



Möjegiň heýkeljigini ýasamagyň zygiderligi.

1



Möjegiň heýkeljigi bölümlere laýyk böleklerе bölünip alynýar.

2

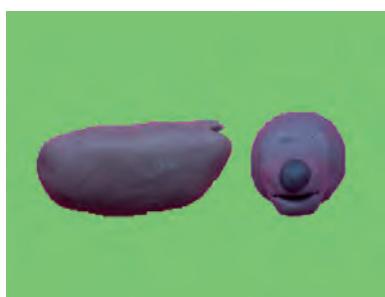

Möjegiň böleklerine şekil berilýär.

3



Möjegiň bölekleri birleşdirilýär.

4



Heýkeljik doly işlenýär.



1. Berlen nusgalara garap tilkiniň we möjegiň heýkeljiklerini ýasaň.
2. Taýýar heýkeljiklerden ertekiniň mazmunyna gabatlap kompozisiýa düzüň.
- 3*. Ertekiniň başga wakasy esasynda kompozisiýa işläň.



«ARÇA BAÝRAMY» TEMASYNDA SURAT ÇEKMEK

Täze ýyl dünýäniň ençeme ýurtlarynda şaklykly garş alynýar. Bezelen arça, aýazbaba we garpamyk täze ýyl baýramynyň nyşanlary hasaplanýar. Göz öňüne getirmeleriňiz esasynda berlen tema boýunça özbaşdak surat çekiň.



1. Suratda nähili görnüş we nämeler suratlanylypdyr?
2. Arça nähili bezelipdir?



Arçanyň suratyny çekmegiň zygiderligi.

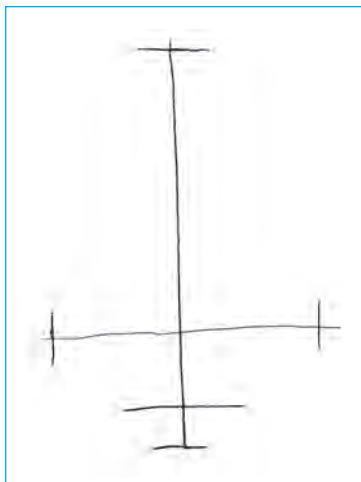

Şekiliň ölçeglerini kesgitlemek.

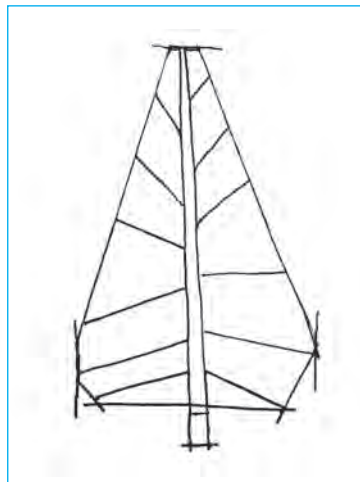

Galamda ilkinji işlemek.

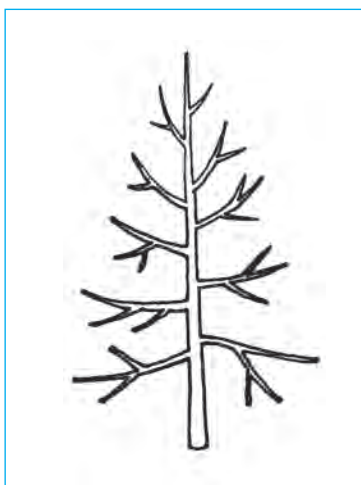

Galamda soňlama işlemek.



Reňkler bilen işlemek.



Arçanyň oýnawaçlarynyň suratyny çekmegiň zygiderliligi.

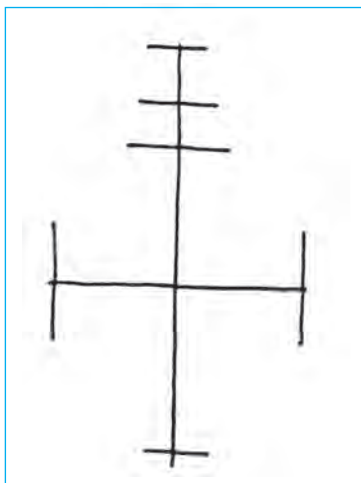

Şekiliň ölçeglerini kesgitlemek.

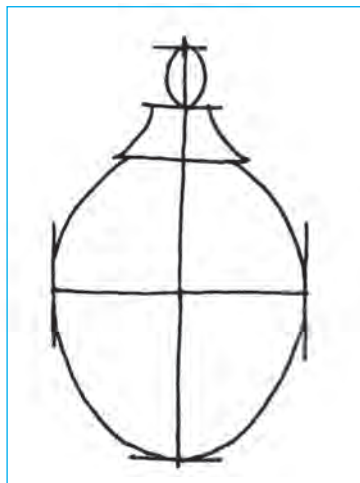

Galamda ilkinji işlemek.

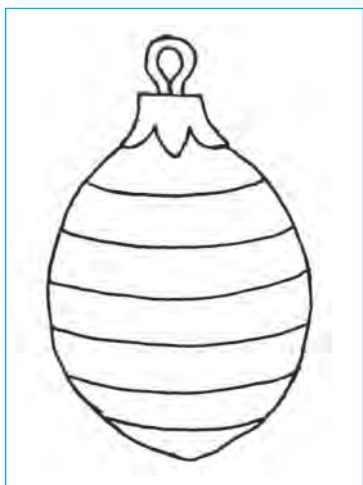

Galamda soňlama işlemek.

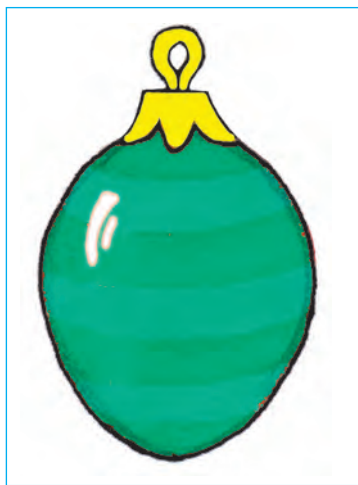

Reňkler bilen işlemek.



Aýazbabanyň suratyny çekmegiň yzygiderliligi.



Şekiliň ölçeglerini kesgitlemek.



Galamda ilkinji işlemek.



Galamda soňlama işlemek.



Reňkler bilen işlemek.



Garpamygň suratyny çekmegiň zygiderligi.

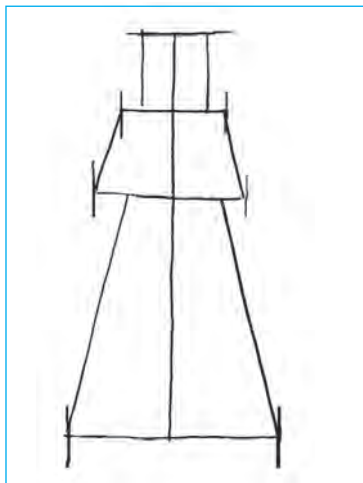

Şekiliň ölçeglerini kesgitlemek.



Galamda ilkinji işlemek.



Galamda soňlama işlemek.



Reňkler bilen işlemek.



Ýokardaky zygiderlilik esasynda surat çekiň.



Garyň bölejikleriniň suratyny çekmegiň yzygiderliligi:

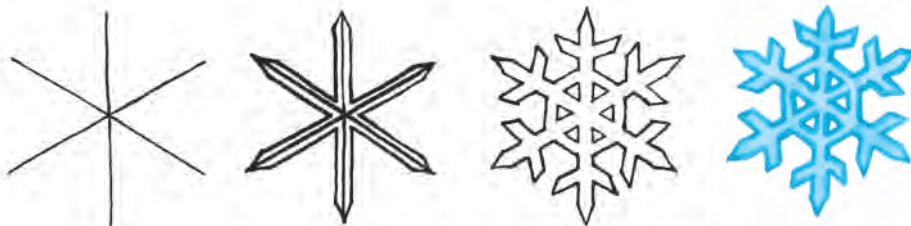

Aşakdaky suratlar ýerleşdirilende nähili ýalňyşlyga ýol berlipdir? Ölçegleri dogry seçilip alnypmy?



Synpda çekilen «Arça baýramy» tema-syndaky kompozisiýany tamamlañ.



ARALYK BARLAG IŞI

I. Test soraglary:

1. Aşakdaky nagyşlardan haýsysy kwadrat şeklinde?



2. Haýsy ertekiniň gahrymany erbet gylkly?



3. Haýsy suratda kompozisiýa suratlandyrylypdyr?



4. Aşakdakylardan haýsy biri žiwopis eseri hasaplanýar?



II. Amaly ýumuş.

Güýzki işler temasyndaky suratlardan peýdalanyp, güýzki miweleri plastilinden ýasap saçak düzüň.

III ÇÄRÝEK



S. Sulaýmanow. *Gyşyň başlanyşy*

Şu çäryekde siz:

- gyş paslyndaky tebigatyň görnüşleriniň suratyny çekmegi;
- sowuk reňkler bilen tanyşyp, olaryň ulanylyşyny;
- haýwanlaryň heýkeljiklerini işlemegi;
- tema esasynda gutlag hatlaryny ýasamagy öwrenersiňiz.

«GYŞYŇ ZYNATY» TEMASYNDA SURAT ÇEKMEK



S. Sulaymanow. Gyş

Gyş — örän ajaýyp pasyl. Hemme ýer apak gara bürenen. Güneş güýçsüz şöhlesini saçýar. Günler sowuk. Daragtlar bireýýäm uka gidipdir. Gargalar iýmit gözlemek bilen başagaý.



1. Ýokardaky suratda nämeler suratlandyrylypdyr?
2. Suratkeş gyş paslyny suratlandyranda köpräk haýsy reňklerden peýdalanypdyr?



Sowuk reňkler:

-  — gök;
-  — mawy;
-  — benewşe;
-  — asman reňk;
-  — ýaşyl.



Sowuk reňkler buz, suw we asmanyň reňklerini ýatladýar. Bu reňklerden köpräk gys paslyny suratlandyrmakda peýdalanylýar.



Aşakdaky suratda haýsy sowuk reňkleriň ulanylandygyny aýdyp beriň.



H. Rozmetow. Gys



«Gyşyň zynaty» temasynda surat çekiň. Munda siz gardan, gyşky oýunlardan, Aýazbabanyň görnüşlerinden peýdalanyp bilersiňiz.



1. Sowuk reňklere haýsy reňkler degişli? Näme üçin olar şeýle atlandyrylýarlar?
2. Älemgoşarda haýsy sowuk reňkler bar?



1. Synpda çekilen «Gyşyň zynaty» suratyny tamamlaň.
- 2*. Synpda çekilen «Gyşyň zynaty» suraty esasynda hekaýa ýazyň.



Bir-birine meňzeş iki aýazbabanyň suratyny tapyň.



ÝÜK MAŞYNYNYŇ SURATYNY ÇEKMEK



Birinji synpda ýeňil awtomaşynlaryň suratyny çekmegi öwrenipdiňiz. Indi bolsa ýük awtomaşynlaryny çekmegi öwrenersiňiz.

Ýük awtomaşynlary dürli ululykda bolýar. Şäherlerde we obalarda peýdalanylýan ýük maşynlary kiçiräk göwrümde bolsa, şäherara uzak ýola gatnaýan awtomaşynlar ulurak bolýar.



1. Nähili ýük maşynlaryny görýärsiňiz?
2. Olar nähili böleklerden ybarat?



Ýük maşynynyň suratyny çekmegiň zygiderligi.

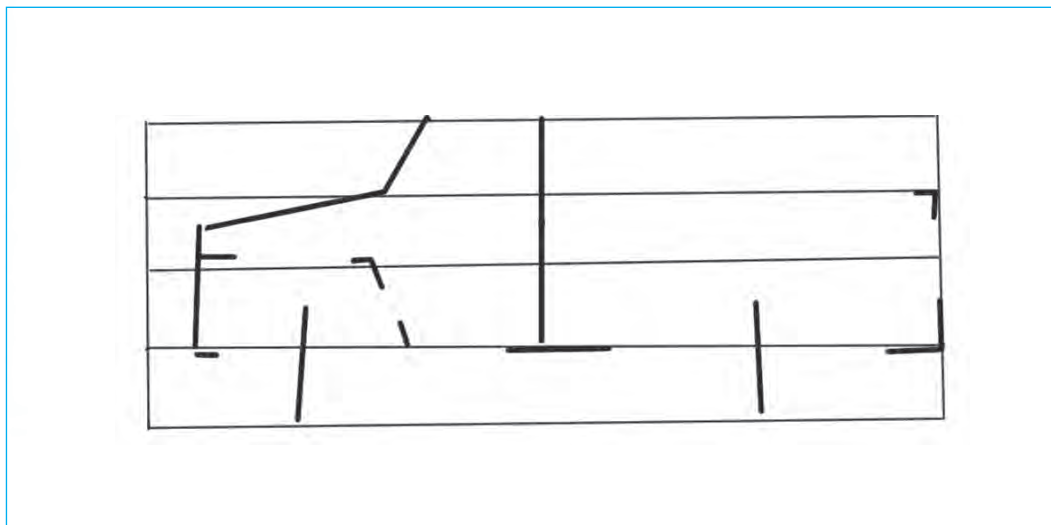

Teswiri kagzya ýerleşdirmek.

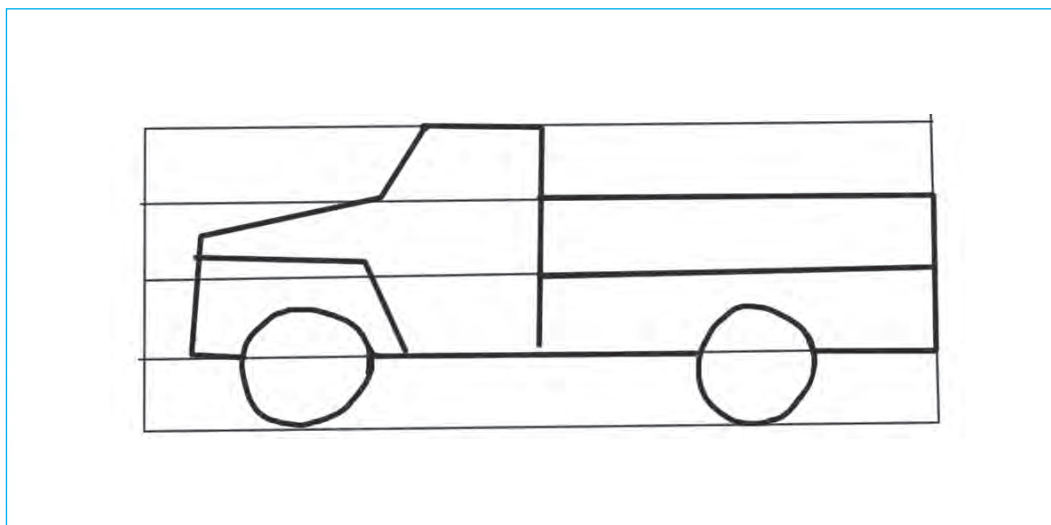

Galamda ilkinji işlemek.



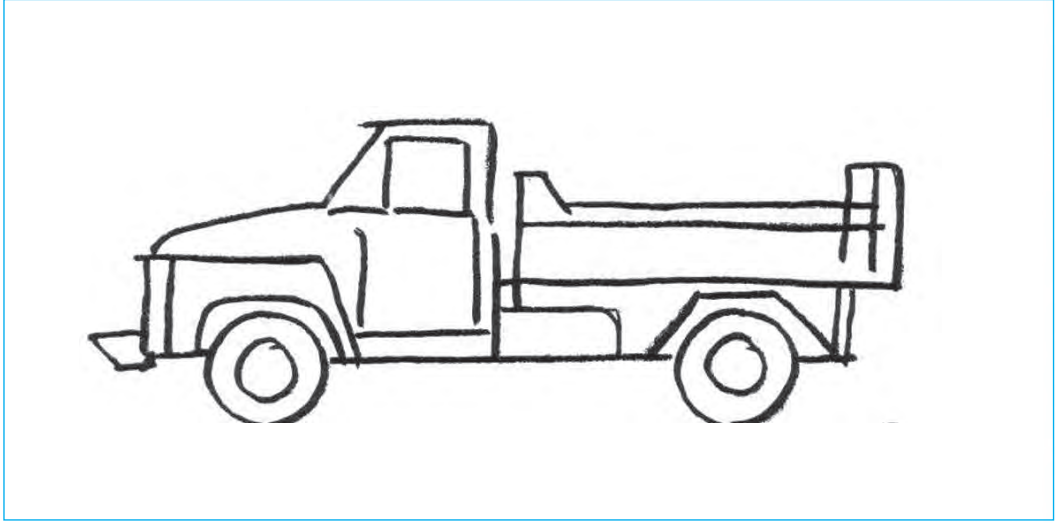

Teswiri galamda doly çekmek.

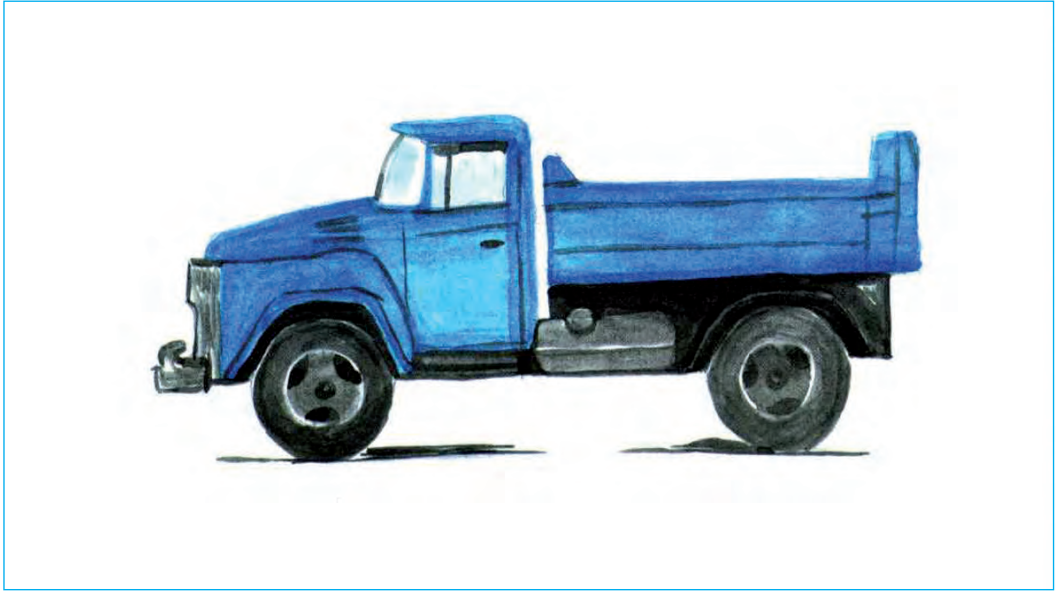

Suraty reňklemek bilen tamamlamak.



Berlen suratlara we nusga garap awtomaşynyň suratyny çekiň.



1. Awtomaşynlar esasan haýsy reňklerde bolýar?
2. Olary suratlandylanda nämelere üns bermeli?



1. Islendik bir awtomaşynyň suratyny çekiň.
- 2*. Plastilinden awtomaşyn ýasaň.



GUŞUŇ SURATYNY ÇEKMEK



Siz guşlary görensiňiz elbetde. Olaryň ýurdumyzda duşýandygy barada telewideniýe arkaly ýa-da haýwanat bagynda tomaşa edensiniňiz.



1. Ýokardaky suratlarda nämeler suratlandyrylypdyr?
2. Olar size ýaradymy? Näme üçin?



Guşuň suratyny çekmegiň yzygiderlilik.

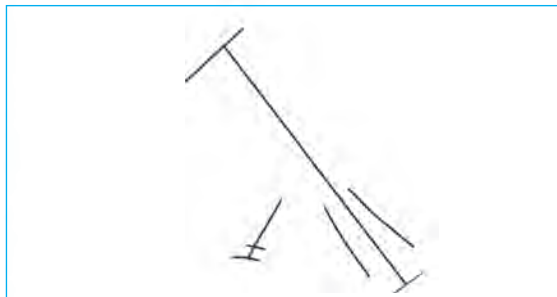

Şekiliň ölçeglerini kesgitlemek.

Galamda ilkinji işlemek.

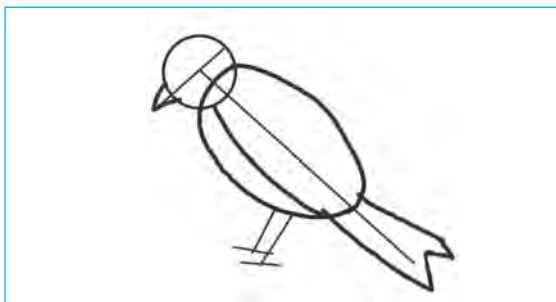

Galamda soňlama işlemek.

Suraty reňklemek.





Uçup barýan garlawajyň suratyny çekmegiň zygiderliligi.

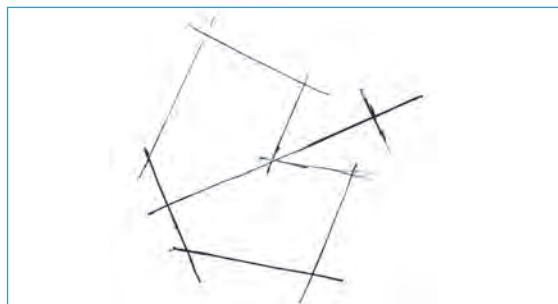

Şekiliň ölçeglerini kesgitlemek.

Galamda ilkinji işlemek.



Galamda soňlama işlemek.

Suraty reňklemek.





«Ganatly dostlar» temasynda hyýaly surat çekiň. Munda guşlaryň şeklini, reňkini, bir-birine görä uly-kiçidigini, olar, esasan, bahar paslynda agaçlaryň şahalaryna höwürtgä gurýandygyny hasaba alyň.



1. Synpda çekilen guşlaryň suratyny tamamlañ.
- 2*. «Ganatly dostlar» temasynda surat çekiň.



ATYŇ (DÜÝE, PIŞIK, PIL ÝALY HAÝWANLARYŇ) HEÝKELINI ÝASAMAK

Tebigatda jandarlar köp. Olar ýabany we öý haýwanlaryna bölünýändigini gowy bilýärsiňiz. Ondan başga-da haýwanlar gurluşyna, reňkine we görnüşine garap hem tapawutlanýar. Her bir adamyň özi halaýan haýwany bolýar.



Atyň heýkelini ýasamagyň zygiderliligi.

1



Heýkeljigiň bölümleri üçin
böleklere bölünýär.

2



Esasy bölegi gyrkylyp,
aýaklar emele getirilýär.

3



Kelle bölegi beden
bölegine birleşdirilýär.

4



Atyň ýaly, guýrugy,
gulaklary ýabşyrylyp doly
işlenýär.



Düýäniň heýkelini ýasamagyň zygiderliligi.

1



Laý ýa-da plastilinden düýäniň heýkeljigi böleklerine laýyklykda bölünýär.

2



Heýkeljigiň esasy bölegi heýkeltaraşlyk pyçagy bilen gyrkylyp aýaklar emele getirilýär.

3



Heýkeljigiň kelle bölegi, örküçleri beden bölegine birleşdirilýär.

4



Heýkeljik soňlama işlenýär.



Özüňiz halaýan haýwanyň heýkelini ýasaň.



Haýwanlaryň heýkelini ýasanda tebigatdaky haýwanlara garaň we nusgada görkezilen usullardan peýdalanyň.

1

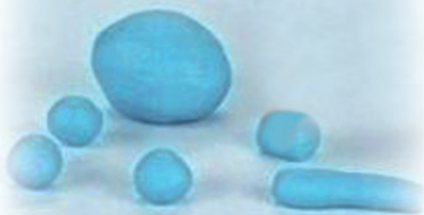

Piliň heýkeljigi böleklerine laýyklykda bölünýär.

2



Piliň böleklerine şekil berlip, birleşdirilýär.

3



Piliň maýda bölekleri birleşdirilýär.

4



Heýkeljik soňlama işlenýär.



Piřigiň heýkelini ýasamagyň zygiderliligi.

1

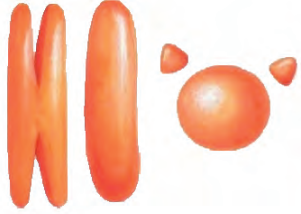

Laý ýa-da plastilinden piřigiň heýkeljigi böleklerine laýyklykda bölünýär.

2



Heýkeljigiň esasy bölegi heýkeltaraşlyk pyçagy bilen gyrkylp aýaklar emele getirilýär.

3



Heýkeljigiň kelle bölegi, guýrugy beden bölegine birleşdirilýär.

4



Heýkeljik soňlama işlenýär.



1. Size haýsy haýwan ýakýar? Näme üçin?
2. Onuň gurluşyny we reňkini aýdyň?



Ýasalan heýkellerden ybarat kompozisiýa düzüň.



NAGYŞ NUSGALARYNDAN NUSGA DÖRETMEK



1. Suratdaky nagyşlara nirelerde duşmak bolar?
2. Olardaky reňkler nähili seçilip alnypdyr?



Sözenelerde kwadrat nagyşlaryň ulanylyşy.



1. Suratdaky sözenä nähili şekildäki teswirlerden bezeg hökmünde peýdalanylýdyr?
2. Onda reňkler nähili saýlanyp alnyldy?
3. Sözenelerde ýene nähili nagyş görnüşleri ulanylýar?



Nagyşda bezeg güllerini ýerleşdirmegiň zygiderligi.

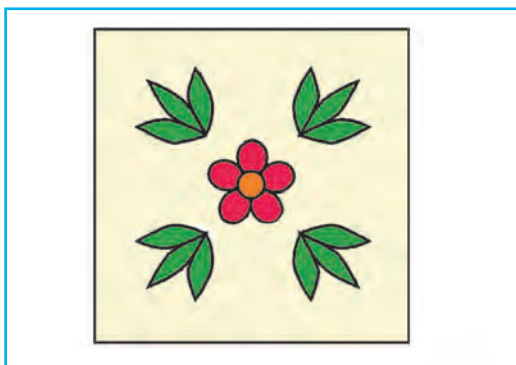
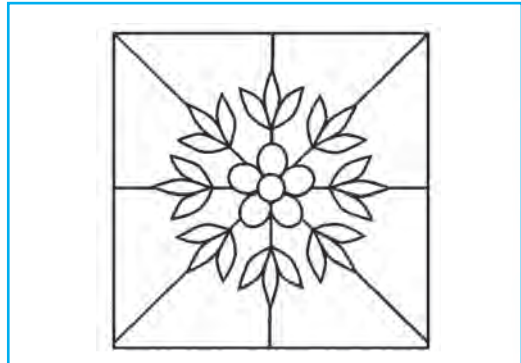
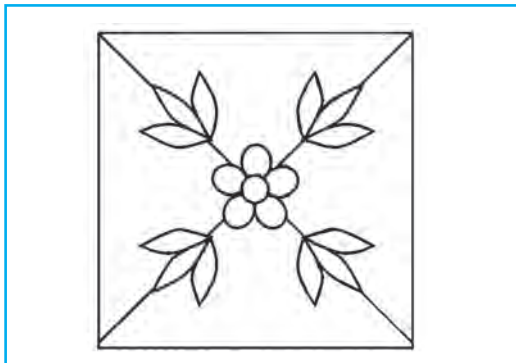
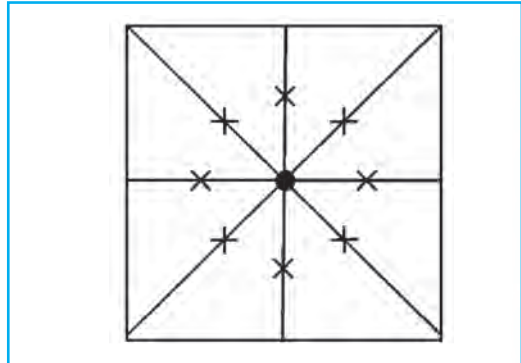
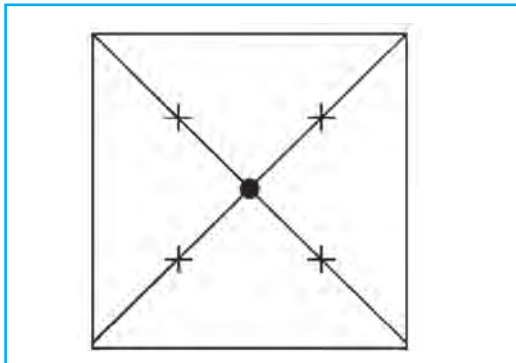
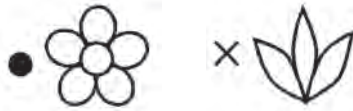



1. Gül bezegi açyk reňkde bolsa, nagşyň esasy doýgun reňkde bolýar.
2. Gül bezegi doýgun reňkde bolsa, nagşyň esasy açyk reňkde bolýar.



47-nji sahypada berlen gül bezeglerinden birini ýa-da birnäçesini saýlap, kwadrat nagyş çyzyň.



1. Tahýada nähili bezeg gülleri aňladylypdyr?
2. Nagyş gülleri reňklenende nämä üns bermeli?
3. Gülli nagyşlar bilen köplenç nämeler bezelýär?



Suratlarda berlen nagyşlardan haýsysynyň kwadrat nagyşlardygyny aýdyň.

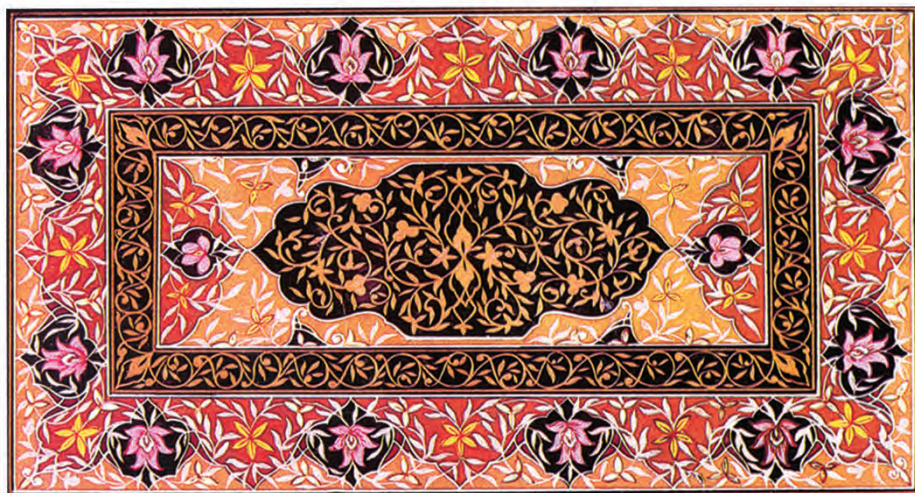

1. Synpda başlanan nagyş çekmegi tamamlañ.
- 2*. Öýüňizdäki halydan nusga alyp, halyňyň suratyny çekiň.



TEGELEK ŐEKILLI NAGYŐ KOMPOZISIÝASYNY ÇYZMAK



1. Nagyőlar nãhili Őekillerde bolýar?
2. Tegelek Őekilli nagyőlara nirelerde duőmak mőmkin?



Tegelek şekilli nagyşlary çyzmagyň yzygiderligi.

1

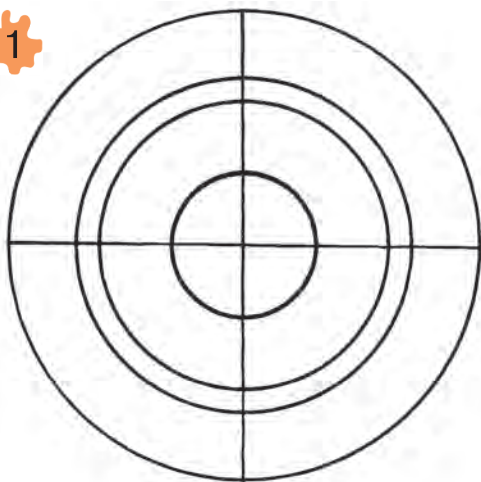

2

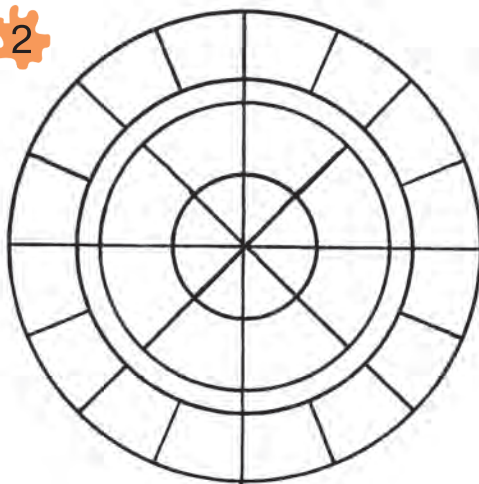

Çyzgysy çyzylýar.

3

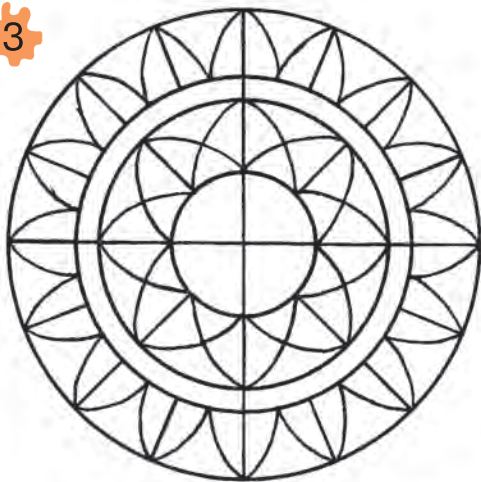

4



Bezeg gülleri çyzylýar.



Tegelek şekilli nagyş kompozisiýasyny çyzyň.



1. Nagyşlarda nähili reňklerden köpräk peýdalanylýar?
2. Tegelek şekilli nagyşlar size ýakýarmy? Näme üçin?



1. Tegelek şekilde çekilen suraty doly tamamlap, reňkläň.
2. Özünüz halaýan nagyş güllerinden ybarat tegelek şekilli nagyş çekiň.



8-NJI MART BAÝRAMYNA GUTLAG HATY ESKIZINI IŞLEMEK



8-nji mart — Halkara aýal-gyzlar baýramy. Bu günü ýer ýüzündäki köp ýurtlaryň halklary baýram edýär.

Özbekistanda hem 8-nji mart günü dynç alyş günü diýlip bellenen. Bu günü mamalara, ejelere hormat edilip, olar sylanýarlar.



1. 8-nji mart günü kimleri gutlaýarsyňyz?
2. Gyzlar, sizi kimler gutladylar?



Gutlag hatynyň eskizini işlemegiň zygiderligi.

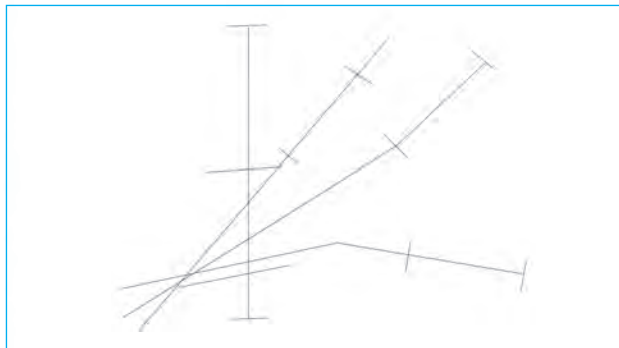

Teswiri kagyza ýerleşdirmek.



Teswiri ilkinji işlemek.



Teswiri galamda doly çyzmak.



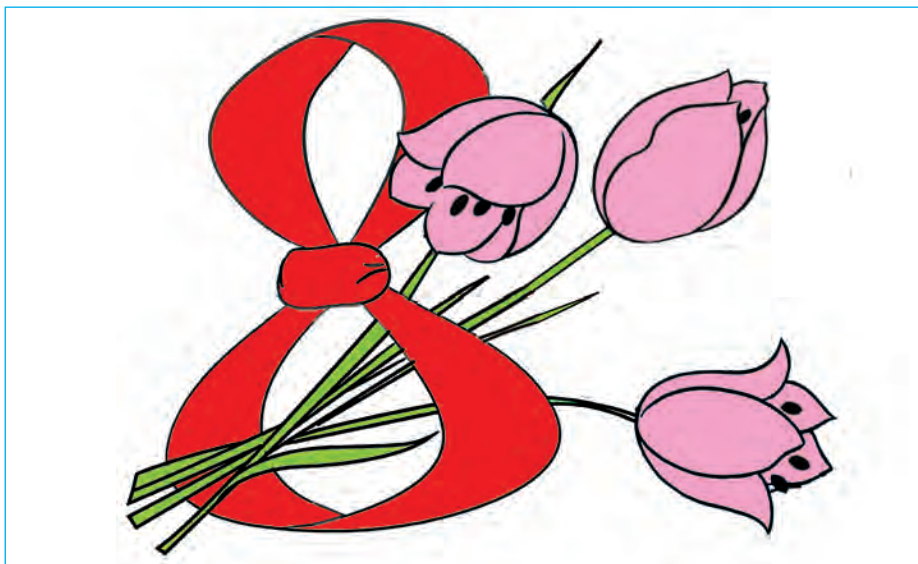

Suraty reňkler bilen doly çekmek.



Berlen gutlag hatlary essasynda gutlag hatyny taýýarlaň.



1. 8-nji marta bagyşlanan gutlag hatynda nä-meleri suratlandyrmak mümkin?
2. Haýsy reňklerden köpräk peýdalanan makul?



1. «8-nji mart baýramy bilen» gutlag hatyny akwarelde boýaň.
2. «8-nji mart» diýlip atlandyrylan islän gutlag hatynyň eskizini çyzyň.



«NOWRUZ — BAHAR BAÝRAMY» TEMASYNDA SURAT ÇEKMEK

Nowruz ýurdumyz garaşsyzlygyny gazanandan soň gaýtadan belleniip başlandy. Nowruz — bahar, täzeleniş baýramydyr. Şonuň üçin Nowruz ýurdumyzda uly şadyýanlyk bilen garşy alynýar. Nowruzyň gelmegi bilen şäherlerimiziň we obalarymyzyň tebigaty gözelleşýär.

Gyrlar we meýdanlar ýap-ýaşyl öwüsýär, reňbe-reň güllere bürenýär.



G. Çernuhin. *Özbek topragy*



Mamalarymyz semeni, halim ýaly milli tagamlary taýýarlaýarlar. Çagalaryň hem baharda söýüp oýnaýan oýunlary köpeliär.



1. Nowruz nähili baýram? Ol hakda aýdyp beriň.
2. Ýokardaky suratda kimler we nämeler suratlандyrylypdyr?



«Nowruz — bahar baýramy» temasynda surat çekiň. Onda kompozisiýa elementlerini dogry ýerleşdirmäge, perspektiwa, zatlaryň reňklerini dogry seçip almaga aýratyn üns beriň.



«Nowruz — bahar baýramy» temasyndaky surat şekillendiriş sungatynyň gündelik durmuş žanryna degişlidir.

Şekillendiriş sungatynyň **gündelik durmuş žanry** diýip, adamlaryň durmuşyndaky wakalary suratlandyrmaga aýdylýar.



1. Suratda görkezilenleri häsiýetlendirin.
2. Siz baýramy nähili göz öňüne getirýärsiňiz?

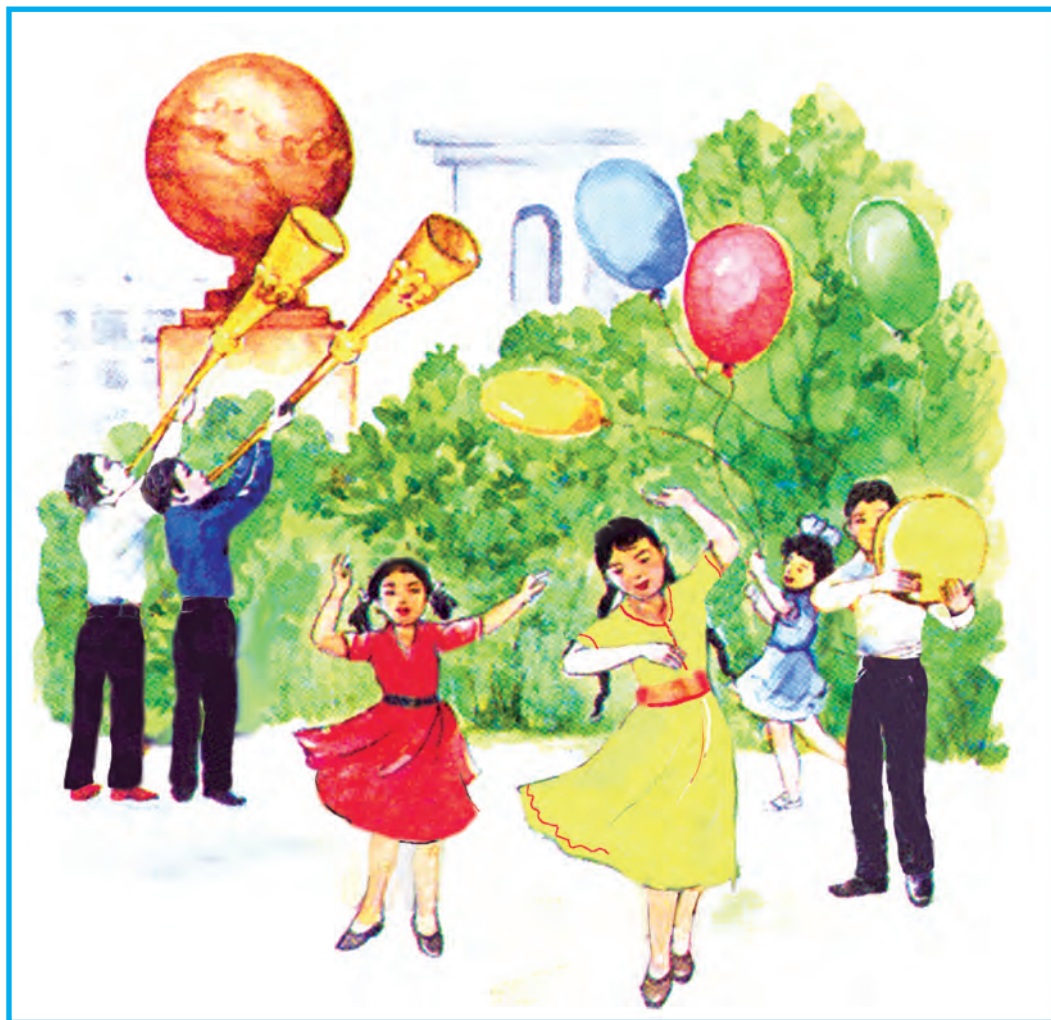

1. Şekillendiriş sungatynyň gündelik durmuş žanrynda nämeler suratlandyrylýar?
2. Baharyň suratynda nähili reňkler köpräk ulanylýar?



«Nowruz — bahar baýramy» temasyndaky suraty doly tamamlañ.



**Rozy
Çaryýew**
(1931–2004)



R. Çaryýew. *Kumkorgan almalary*

Rozy Çaryýew — Özbegistanyň Çeper Akademiýasynyň akademigi, Özbegistanyň halk suratkeşi. Ol portret, taryhy we gündelik durmuş žanrynda döredijilik edipdir. Suratkeşiň gündelik durmuş žanryndaky «Söhbet», «Humsan agşamy», «Naý», «Çopan oylan» we başga eserleri meşhurdyr.



«MENIŇ MEKDEBIM» TEMASYNDA SURAT ÇEKMEK



Biziň ýurdumyzda okuwçylaryň gowy bilim almaklary üçin ähli şertler döredilendir.



1. Suratda nämeleri görýärsiňiz?
2. Suratdaky mekdebiň gurluşy, şekli we ölçegleri nähili?



Jaýyň suratyny galamda çekmegiň zygiderligi.

1

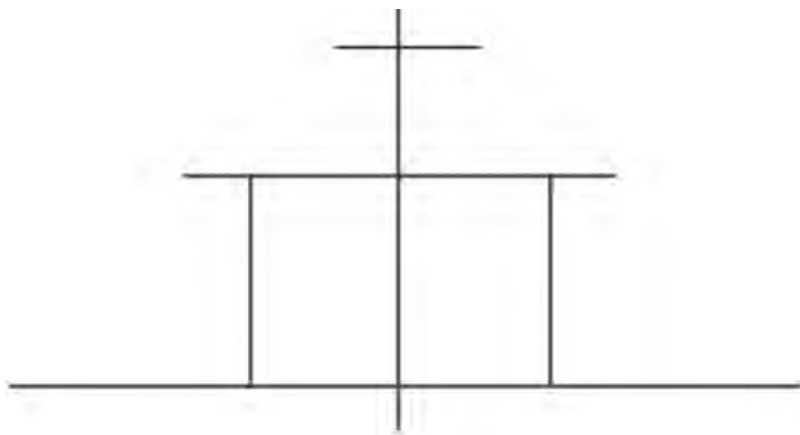

Şekiliň ölçeglerini kesgitlemek.

2



Galamda ilkinji çyzgy çyzmak.



3



Şekli galamda tamamlamak.

4



Şekli reňlemek.



Mekdep howlusyna çykyp, oňa syn ediň. Synpda ýönekeý gara galamyň kömeginde «Meniň mekdebim» temasynda surat çekiň.



1. Mekdebiň suratyny çekende esasy ünsi nämelere bermeli?
2. Gara galamyň kömeginde doýgun reňkleri nädip almak bolar?



1. Synpda çekilen «Biziň mekdebimiz» atly surata galamda soňlama bezeg beriň.
- 2* . «Biziň mähellämiz» temasynda surat çekiň.



ARALYK BARLAG IŞI

I. Test soraglary:

1. Dörtburçluk şeklindäki nagyş getirilen bendi anyklaň:

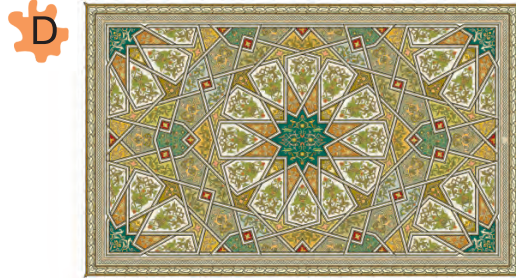

2. Sowuk reňkler dogry görkezilen bentleri anyklaň:

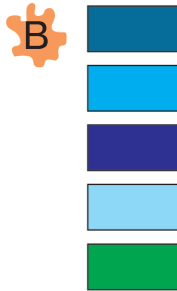

3. Heýkel ýasamagyň basgançaklaryny dogry zygiderlikde ýerleşdiriň.

A



B



D



E



4. Haýsy bentde ýol-ýol nagyş ulanylan?

A



B



D



E



II. Ýumuş.

Özüňiziň işlän «Nowruz – bahar baýramy» suratyňyz hakda hekaýa edip beriň.



IV ÇÄRÝEK



Şu çärýekde siz:

- heýkel ýasamak başarnyklaryňyzy has-da kämilleşdirersiňiz;
- erteki esasynda heýkellerden ybarat kompozisiýalary işlärsiňiz;
- tema esasynda žiwopis işlemegi dowam etdirersiňiz;
- bahar paslyndaky tebigatyň görnüşiniň suratyny çekersiňiz.

AGAÝYŇ ÝAPRAGYNYŇ SURATYNY ÇEKMEK



1-nji synpda ýönekeý gurluşdaky agajyň ýapragyny çekmegi öwrenipdiňiz. Indi çylşyrymly gurluşly ýapraklaryň suratyny çekmegi öwrenersiňiz. Beýle ýapraklara üzüm, çynar, injir, hoz ýalylaryň ýapragy mysal bolup biler.



Berlen agaç ýapraklarynyň gurluşyna, şekline we bir-birinden nähili tapawutlanýandygyna üns beriň!



Çynar agajynyň ýapragynyň suratyny çekmegiň yzygiderligi.



Teswiri kagyza ýerleşdirmek.



Galamda ilkinji işlemek.

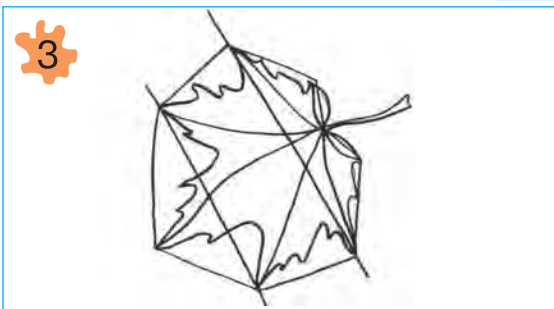

Teswiri galamda doly çekmek.



Teswiri reňk bilen tamamlamak.



Dub agajynyň ýapragynyň suratyny çekmegiň yzygiderligi.

1

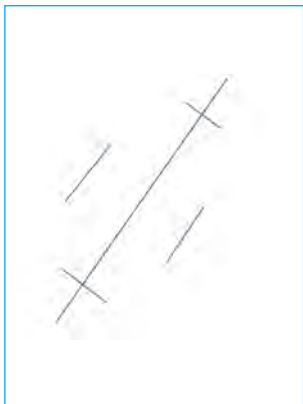

Teswiri kagyza
ýerleşdirmek.

2



Galamda ilkinji
işlemek.

3



Teswiri galamda
doly çekmek.

4



Teswiri reňk bilen
tamamlamak.



Siz bu suratlardan peýdalanyň, özüňiz islän
ýapragyň suratyny çekiň.



Özüňiz halaýan ýapragyň suratyny reňkläň.



«ŞALGAM» ERTEKISI ESASYNDA HEÝKEL ÝASAMAK

Bir bar eken, bir ýok eken, gadym zamanda daýhan baba şalgam ekipdir.
Şalgam ullakan bolup ösüp ýetişipdir.



Baba şalgamy çekip almakçy bolupdyr.
Çeke-çeke ýerden goparyp bilmändir. Şonda
baba mamany kömege çagyrypdyr. Mama

babany, baba şalgamy çeke-çeke goparyp bilmändirler. Mama agtygyny kömege çagyrypdyr, agtygy güjügi, güjük pişigi çagyrypdyr. Pişik bolsa syçany çagyrypdyr.

Syçan pişigi, pişik güjügi, güjük agtygy, agtygy mamasyny, mamasy babasyny, baba şalgamy çekip-çekip ahyrynda goparypdyrlar.



«Şalgam» ertekisiniň gahrymanlarynyň heýkellerini plastilinden 6–7 okuwçy bilelikde ýasaň. Olary dürli usullardan peýdalanyp ýasaň.

Ýasalan heýkelleri ertekiniň mazmunyna görä dürlüçe ýerleşdirmek bolar.

Meselem, diňe şalgamy we gojany ýerleşdirsek ertekiniň bir görnüşi emele gelýär.

Başgaçarak ýerleşdirsek ertekiniň başga görnüşini alarys.



«Şalgam» ertekisiniň gahrymanlarynyň heýkelini aýry-aýry böleklerden ýasamagyň usuly.



Şalgam.



Gyzjagaz.

Kempir.

Goja.



Güjük.



Pişik.



Syčan.



1. Kompozisiya näme?
2. «Güýç – agzybirlilikde» nakylyny «Şalgam» ertekisi esasynda düşündiriň.



1. Özüňiz halaýan erteki gahrymanlarynyň heýkellerinden peýdalanyp ertekiniň mazmunyna laýyk başga kompozisiya düzüň.
- 2*. «Meniň halaýan ertekim» gahrymanlarynyň heýkellerini ýasaň.



DÜÝÄNIŇ SURATYNY ÇEKMEK

Gündogar halklary gadymda Beýik ýüpek ýoly arkaly düýe kerweninde sähralardan geçip, adamlaryň durmuşy üçin zerur bolan önümleri uzak ölkelerden ýurdumyza getiripdirler. Şonuň üçin «kerwen» diýlende düýeler göz öňümize gelýär.



B. Hajimatow. *Kerwen*



1. Kerwen barada nämeleri bilýärsiňiz?
2. Suratda nähili görnüş we nämeler suratlandyrylypdyr?
3. Bu surat şekillendiriş sungatynyň haýsy görnüşine degişli?



Düýäniň suratyny çekmegiň zygiderligi.

1



Teswiri kagyza ýerleşdirmek.

2

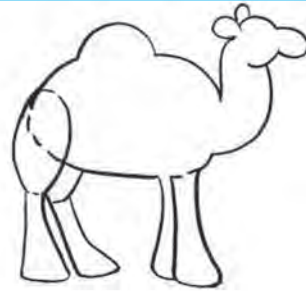

Teswiriň ölçeglerini kesgitlemek.

3

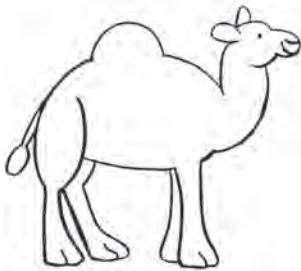

Teswiri galamda doly çekmek.

4

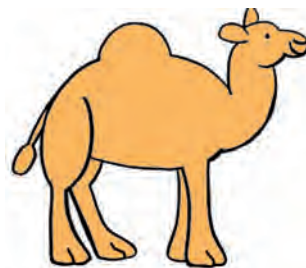

Teswiri reňk bilen doly tamamlamak.





Berlen suratlardan peýdalanmak bilen düýäniň suratyny çekiň.



K. Zommer. *Gündogaryň syýahatçylary*



1. Düýeler nähili görnüşde bolýar?
2. Olaryň görnüşlerini bilýärsiňizmi?



Aşakdaky suratlar çekilende nähili ýalňyşlar goýberilipdir?



1. Düyäniň suratyny reňkläň.

2*. Iki örküçli düýäniň suratyny çekiň.



«BABAMYŇ BAGY»
TEMASYNDA SURAT
ÇEKMEK

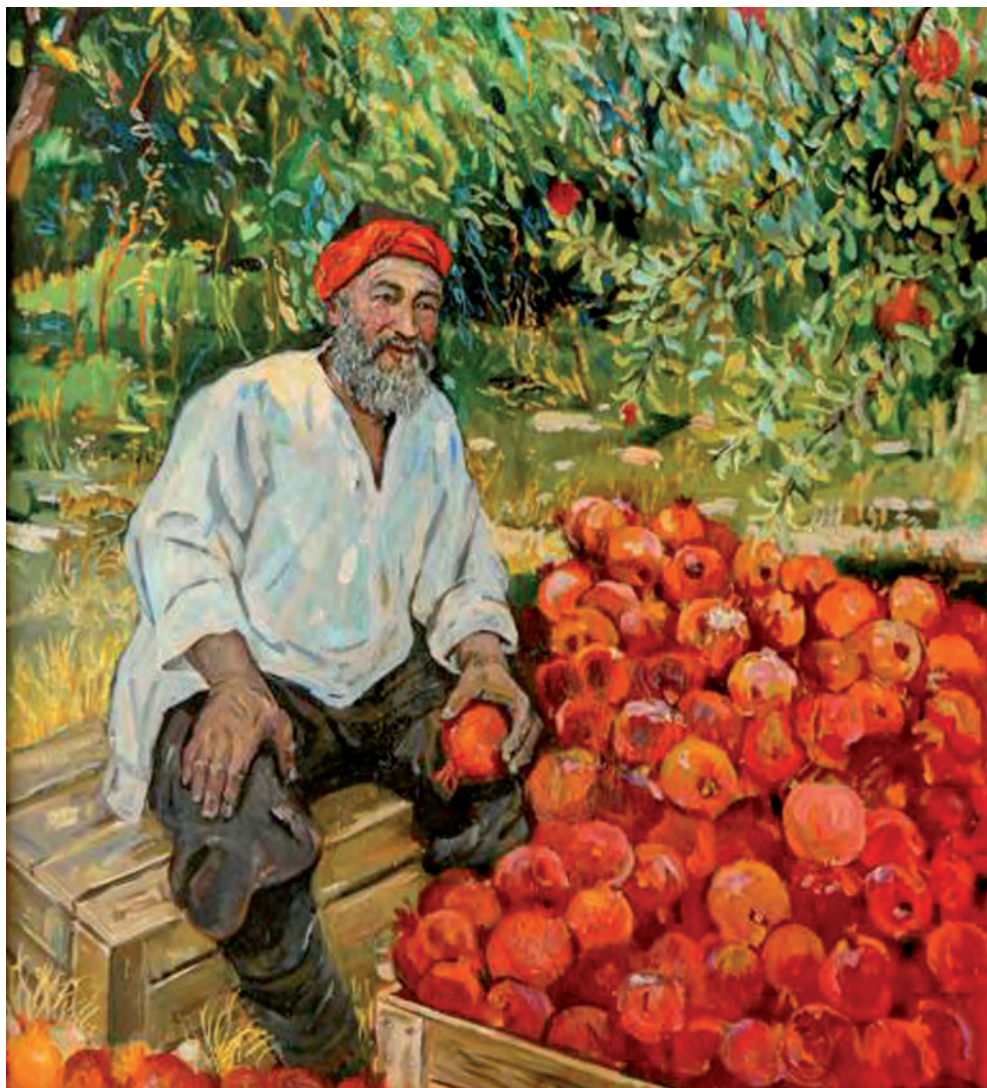

R. Ahmedow. *Bagda*



1. Fotosuratlarda haýsy pasyallar suratlandyrylypdyr?
2. Paslyň özgermegi bilen reňkleriň hem üýtgeýändigini düşündiriň.



h. Rahmanow. *Tomsuň lezzeti*

Aşakdaky suratlary üns berip synlaň we olary aýry-aýry düşündiriň. Soňra şu suratlary bir-biri bilen deňeşdiriň. Olara reňklerden pa-syllary aňladýan serişde hökmünde peýdalan-nylan. Siz hem surat çekeniziňizde reňklerden dogry peýdalanmaga çalyşyň.



1. Suratlarda haýsy pasyl suratlandyrylypdyr?
2. Haýsy pasyl suratlandyrylanda suratkeş haýsy reňkden köpräk peýdalanylypdyr? Sebäbi nämede diýip pikir edýärsiňiz?



«Babamyň bagy» temasynda surat çekiň.



«Babamyň bagy» temasyndaky suraty çekmegiň yzygiderligi.

1



Teswiri kagyza ýerleşdirmek.

2

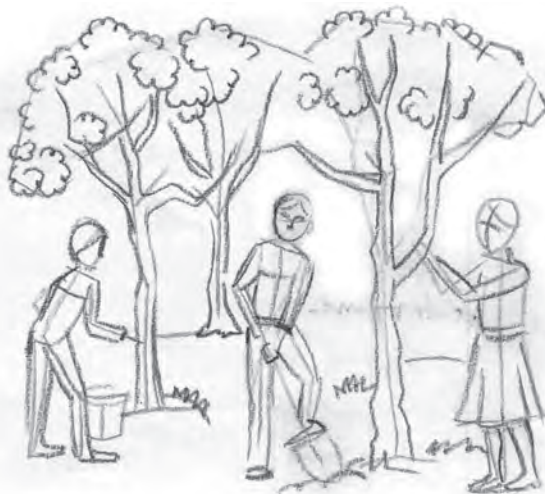

Teswiri aýdyňlaşdyrmak.

3



Teswiri galamda tamamlamak.

4



Teswiri reňkler bilen doly çekmek.



1. Ýylyň dört paslynda mekdep howlusynda bolýan özgerişleri ýada salyň we aýdyp beriň.
2. Her bir pasyl suratlandyrylanda köpräk ulanylýan reňkleri sanaň.



1. Synpda çekilip başlanan «Babamyň bagy» temasyndaky suraty ahyryna ýetiriň.
- 2* . Bagyň käbir pasyldaky suratyny çekiň we ony öň çekilen surat bilen deňeşdiriň.



L. Abdullaýew. Üzüm



«ÜÇ JÜÝJE WE ÖRDEJIK» GOŞGUSY ESASYNDA HEÝKEL ÝASAMAK



Üç jüýje we ördejik

(Goşgudan bölek)

S. Abdukahhar

...Köprini tapyp bilmän,
Üç jüýje boldy haýran.
Neneň aňryk geçeris:
Pikirlendi üç dogan.

...Şol wagt olaň ýanyňa
Geläýdi bir ördejik.
Özi kiçi, sap-sary,
Jüýjelerden eýjejik.

...Hemmesini geçirdi,
Indi dost bolup ýaşar.
Üç jüýje, bir ördek,
Gaýgy-gamsyz oýnaşar.



Suratda nähili waka teswirlenipdir?



Jüýjäniň heýkelini (oýnawaç jüýjä garap) ýasamagyň zygiderliligi.

1



2



3



Ördegiň heýkelini (oýnawaç ördege garap) ýasamagyň zygiderliligi.

1



2



3





«Üç jüýje we ördejik» goşgusy esasynda heýkeltaraşlyk kompozisiýasyny döretmek.



Esasyny ýasamak.



Heýkelleri ýerleşdirmek.



Toparlara bölünip, «Üç jüýje we ördejik» goşgusy esasynda jüýje we ördejikleriň heýkellerini ýasaň.



1. Ýasalan heýkelleri goşgynyň mazmunyna laýyklykda ýerleşdirip, kompozisiýa düzüň.

2*. «Üç jüýje we ördejik» goşgusy esasynda surat çekiň.



JEMLEÝJI BARLAG IŞI

I. Test soraglary:

1. Haýsy suratda şekil dogry ýerleşdirilipdir?

A



B



Ç



D



2. Haýsy suratda ýol-ýol nagyş ulanylypdyr?

A

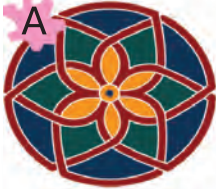

B



Ç



3. Haýsy surat dogry çekilipdir?

A



B



Ç



D



4. Kwadrat sekilli nagyşlary anyklaň:



5. Haýsy bentde heýkeltaraşlyk kompozisiýasy berlipdir?



6. Aşakdaky surat žanrlarynyň yzygiderligi haýsy jogapda dogry berlipdir?

A.

1. Peýzaž.
2. Portret.
3. Natýurmort.

B.

1. Peýzaž.
2. Natýurmort.
3. Portret.

Ç.

1. Natýurmort.
2. Portret.
3. Peýzaž.



7. Ertekilere işlenen illýustrasiýalaryň yzygiderligi haýsy jogapda dogry berlipdir?

A.

1. «Külçe».
2. «Şalgam».
3. «Balary bilen siňek».

B.

1. «Şalgam».
2. «Balary bilen siňek».
3. «Külçe».

Ç.

1. «Balary bilen siňek».
2. «Şalgam».
3. «Külçe».



II. Ýumuş.

Geçen sapakda işlenen «Babamyň bagy» suratynyň tanyşdyryş dabarasyny geçiriň.

MAZMUNY

I ÇÄRÝEK

Reňkler we öwüşginler.....	5
Miweleriň suratyny çekmek.....	10
Peýzažyň suratyny çekmek.....	15
Mugallymlar baýramyna gutlag haty eskizini işlemek.....	20
«Külçe» ertekisi esasynda heýkel ýasamak.....	23
Halk amaly sungaty.....	27
«Güýz geldi» temasynda surat çekmek.....	32
Arylyk barlag işi.....	37

II ÇÄRÝEK

Balygyň heýkeljigini ýasamak.....	40
«Güýzki işler» temasynda surat çekmek.....	43
Ýol-ýol nagyş çekmek.....	46
«Tilki bilen möjek» ertekisi esasynda heýkel ýasamak.....	51
«Arça baýramy» temasynda surat çekmek.....	55
Arylyk barlag işi.....	61

III ÇÄRÝEK

«Gyşyň zynaty» temasynda surat çekmek.....	64
Ýük maşynynyň suratyny çekmek.....	67
Guşuň suratyny çekmek.....	71



Atyň (düýe, pişik, pil ýaly haýwanlaryň) heýkelini ýasamak.....	75
Nagyş nusgalaryndan nusga döretmek.....	79
Tegelek şekilli nagyş kompozisiýazyny çyzmak.....	84
8-nji mart baýramyna gutlag haty eskizini işlemek.....	87
«Nowruz – bahar baýramy» temasynda surat çekmek.....	90
«Meniň mekdebim» temasynda surat çekmek.....	95
Aralyk barlag işi.....	99

IV ÇÄRÝEK

Agajyň ýapragynyň suratyny çekmek.....	102
«Şalgam» ertekisi esasynda heýkel ýasamak.....	105
Düýäniň suratyny çekmek.....	109
«Babamyň bagy» temasynda surat çekmek.....	113
«Üç jüýje we ördejik» goşgusy esasynda heýkel ýasamak.....	119
Jemleýji barlag işi.....	122

**MUYASSAR ISOQOVA, RAHIM HASANOV,
BAHODIR HAYDAROV, ASQARALI SULAYMANOV,
SAODAT JUMANIYAZOVA, ABDUMANNOB ROZIQOV**

TASVIRIY SAN'AT

(Turkman tilida)

*Umumiy o'rta ta'lim maktablaringing
2-sinfi uchun darslik*

Qayta ishlangan va to'ldirilgan
beshinchi nashri

Terjime eden **Kamiljan Hallyýew**
Redaktor **Jumanazar Metýakubow**
Suratçy **Aziz Safarow**
Çeper redaktorlar **Azamat Ýuldaşew,**
Nasiba Ýakubowa
Tehredaktor **Ýelena Toloçko**
Korrektor **Jumanazar Metýakubow**

Lisenziya nomeri AI № 163. 09.11.2009. Çap etmäge 2018-nji ýylyň 23-nji aprelinde rugsat edildi. Ölçeği 70×90^{1/16}. Ofset kagyzy. «Arial CE» garniturasy. Kegli 16, 14. Şertli çap listi 9,36. Neşir listi 10,62. 969 nusgada çap edildi. Şertnama № 46–2018. Buýurma №

Özbeğistanyň Metbugat we habar agentliginiň Çolpan adyndaky neşirýat-çaphana dördijilik öýünde taýýarlandy. 100011, Daşkent, Nowaýy köçesi, 30.
Telefon: (371) 244-10-45. Faks: (371) 244-58-55.

Özbeğistanyň Metbugat we habar agentliginiň G'afur G'ulom nomidagi neşirýat-çaphana dördijilik öýünde çap edildi. 100128, Daşkent, Labzak köçesi, 86.

T 27 **Şekillendiriş sungaty** [Tekst]: 2-nji synp üçin derslik. /M. Isakowa [we başg.] – Gaştdan işlenen we doldurylan başinji neşir. – D.: Çolpan adyndaky NÇDÖ, 2018 – 128 s.
ISBN 978-9943-05-837-8

UO'K 372.87=512.164(075)
KBK 85.15ya71

Ulanmaga berlen okuw kitabynyň ýagdaýyny görkezýän jedwel

No	Okuwçynyň ady familiýasy	Okuw ýyly	Okuw kitabyny alan wagtyndaky ýagdaýy	Synp ýolbaşçy-synyň goly	Okuw kitabyny tabşyrandaky ýagdaýy	Synp ýolbaşçysynyň goly
1						
2						
3						
4						
5						
6						

Okuw kitaby ulanmaga berlip, okuw ýylynyň ahyrynda gaýtaryp alnanda ýokarky jedwel synp ýolbaşçysy tarapyndan aşakdaky bahalamak tertibine esaslanyp doldurylýar:

Täze	Okuw kitabynyň ilkinji gezek peýdalanmaga berlendäki ýagdaýy
Ýagşy	Jilti gowy, okuw kitabynyň esasy böleginden bölün-medik. Ähli sahypalary bar, ýyrtylmadyk, sahypalarynda ýazgylar we çyzgylar ýok.
Kanagatlanarly	Jilti ýenjilen, kä ýerleri çyzylan, gyralary gädilen, okuw kitabynyň esasy böleginden bölek ýerleri bar, peýdalanyjy tarapyndan kanagatlanarly derejede abatlanypdyr. Goparlan sahypalary ýelimlenen, käbir sahypalary çyzylan.
Kanagatlanarsyz	Jilti çyzylan, ýyrtyk, esasy böleginden aýrylan, ýyrtylan ýeri düşüp galan, kanagatlanarsyz derejede abatlan. Sahypalary ýyrtylan, listleri ýetişmeýär, çyzyp taşlanan. Okuw kitabyny gaýtdan dikeldip bolmaýar.